

VUPS

VIGOUR[®]

Gas Control Solution

ULTRA HIGH PURITY GAS SYSTEM

**Gas
Control
Solution**

Elgiloy® is registered trademark of Elgiloy Specialty Metals.
Hastelloy® is registered trademark of Haynes International, Inc.
Viton® and Kalrez® are registered trademarks of Dupont.
VespeI® is registered trademark of Dupont Specialty Metals.

Table Of Contents |



Regulators for UHP Applications | P1~36

| | |
|-----------------------|--------|
| VSR-50UB / UC Series | p1~4 |
| VSR-100UB / UC Series | p5~8 |
| VSR-210UB / UC Series | p9~12 |
| VSR-410UB / UC Series | p13~16 |
| VSR-510UB / UC Series | p17~20 |
| VSR-610UB / UC Series | p21~24 |
| VSR-710UB / UC Series | p25~28 |
| VSR-910UB Series | p29~30 |
| VSR-911UB Series | p31~32 |
| VSR-920UB / UC Series | p33~36 |

Diaphragm Valves | P37~54

| | |
|----------------|--------|
| VDV31UA Series | p37~38 |
| VDV32UA Series | p39~40 |
| VDV33UA Series | p41~42 |
| VDV31UB Series | p43~44 |
| VDV32UB Series | p45~46 |
| VDV33UB Series | p47~49 |
| VDV52 Series | p50~52 |
| VDV36 Series | p53~54 |

Metering Valves | P55~57

All-Welded Check Valves | P58

Bellows Valves | P59~60

Vacuum Generators | P61~62

Gas Stick Assemblies | P63~65

Filters | P66

Gasket Filters | P67

VFS face seal fittings | P68~76

| | |
|---------------------|--------|
| Glands | p70~71 |
| Nuts | p72 |
| Gaskets | p73 |
| Caps,Plugs,Coupling | p74 |
| Bodies | p75~76 |

Micro Weld Fittings | P77~79

| | |
|------------|--------|
| VMW Series | p77~79 |
|------------|--------|

Tube Butt Weld Fittings | P80~82

| | |
|------------|--------|
| VTW Series | p80~82 |
|------------|--------|

Weld Assemblies | P83

| | |
|------------|-----|
| VWR Series | p83 |
|------------|-----|

Cylinder Connections | P84~86

| | |
|------------|--------|
| VUC Series | p84~86 |
|------------|--------|

Gauges | P87~90

Single Stage Pressure Regulators

VSR-50UB Series

Product Feature

- Single-stage pressure regulator
- 10µin. Ra surface finish (25µin. Ra optional)
- Minimized internal volume for short purge times
- All gas-wetted parts made of stainless steel SS 316L, Hastelloy C276 and PCTFE respectively
- Internal connectors for pressure gauges
- Flow capacity: to 15 slpm(standard), to 30 slpm(option)
- 100% helium-leak-tested



Dimensions (mm)

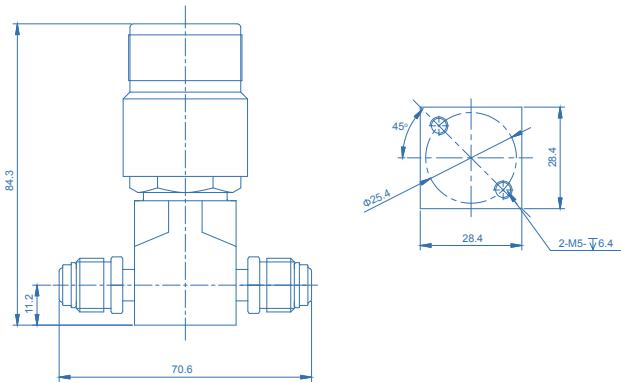

Flowchart

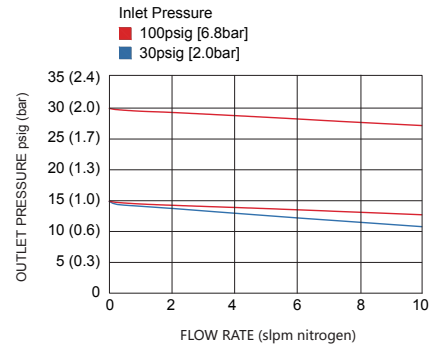

Technical Data

| | |
|----------------------------------|---|
| Type: | single-stage |
| Inlet pressure P ₁ : | Vacuum to 150 psig |
| Outlet pressure P ₂ : | 10/30/60/100 psig |
| Surface finish: | 10µin. Ra (25µin. Ra optional) |
| Materials | |
| Body: | see ordering info |
| Valve seat: | PCTFE (Vespel® optional) |
| Diaphragm: | Hastelloy® C276 |
| Inlets and Outlets: | 1/4" face seal and tube weld |
| Temperature range: | -40°F to +160°F (-40°C to +71°C) |
| Leak rate: (to atmosphere) | 1x10 ⁻⁹ mbar l/s He |
| (via seat) | 1x10 ⁻⁸ mbar l/s He |
| Flow capacity: | Cv=0.06 (Cv=0.1 option) |
| Weight: | approx. 1.35kg (depending on connections or options) |
| Supply pressure effect: | 0.2 psig rise in delivery pressure per 20 psig source pressure drop @Cv=0.06 0.4 psig rise in delivery pressure per 20 psig source pressure drop @Cv=0.1 |

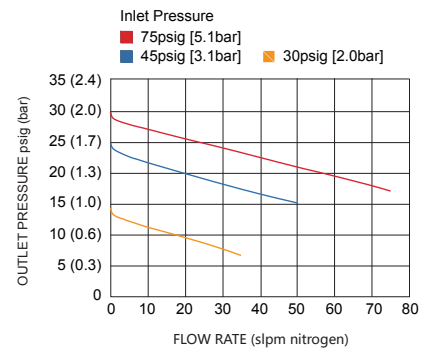

Single Stage Pressure Regulators VSR-50UB Series

Ordering Information

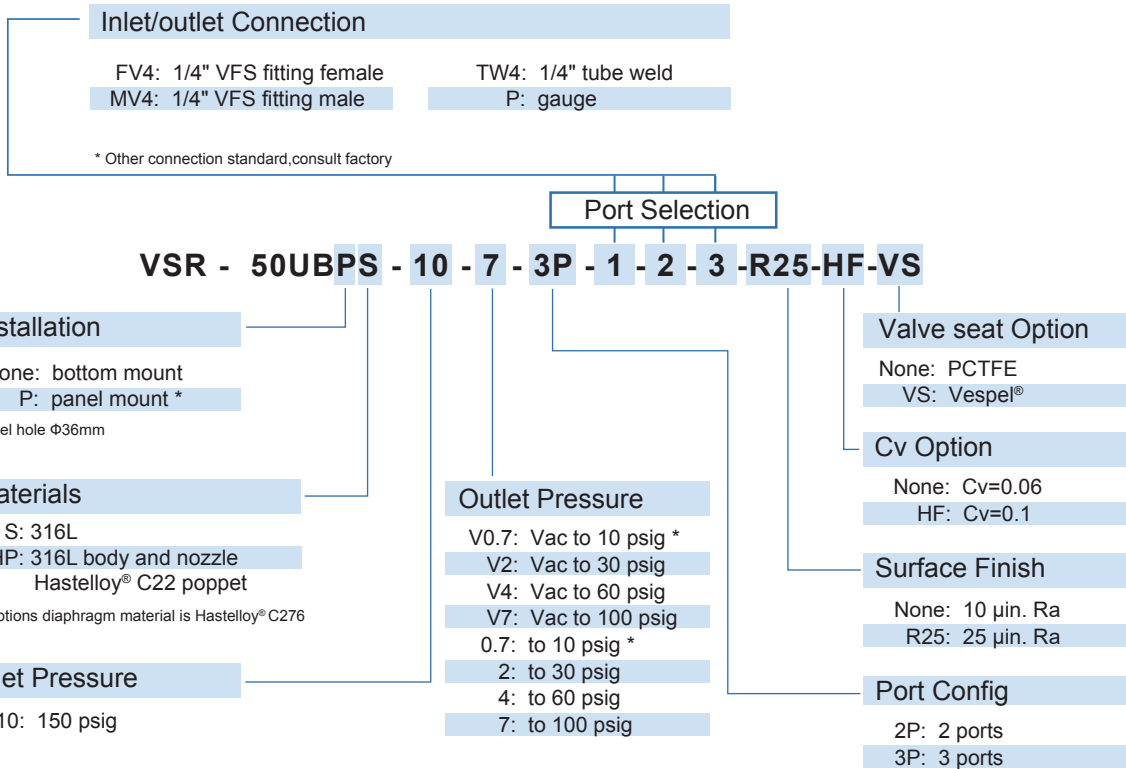
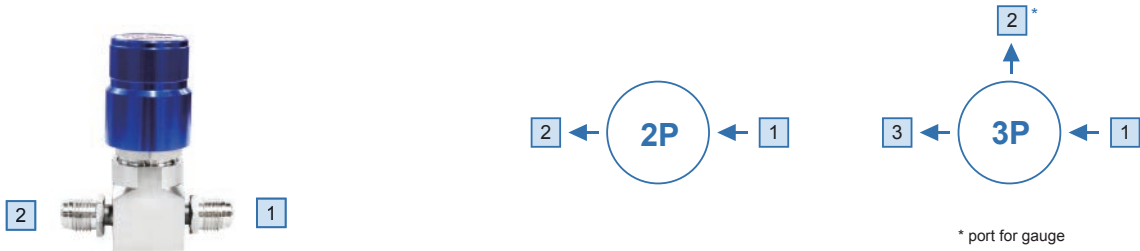

Ordering Example

VSR - 50UBS - 10 - 7 - FV4 - P - FV4
 1 - 2 - 3



Single Stage Pressure Regulators

VSR-50UC Series

Product Feature

- Single-stage pressure regulator
- 15µin. Ra max, 10µin Ra average surface finish (10µin. Ra max, 7µin. Ra max. 5µin. Ra max optional)
- Minimized internal volume for short purge times
- All gas-wetted parts made of stainless steel SS 316L, Hastelloy C276 and PCTFE respectively
- Internal connectors for pressure gauges
- Flow capacity: to 15 slpm(standard), to 30 slpm(option)
- 100% helium-leak-tested



Dimensions (mm)

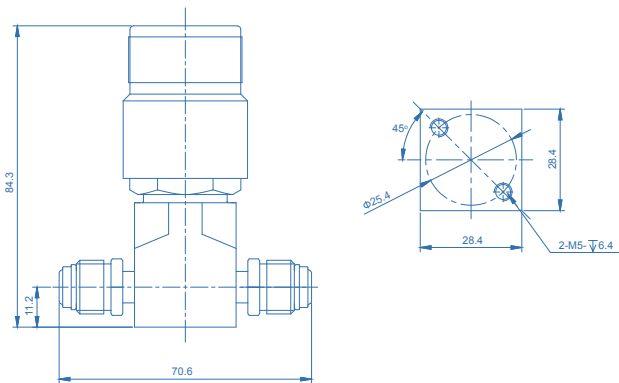

Flowchart

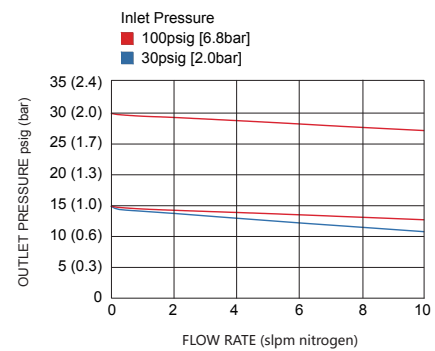

Technical Data

| | |
|----------------------------------|---|
| Type: | single-stage |
| Inlet pressure P ₁ : | Vacuum to 150 psig |
| Outlet pressure P ₂ : | 10/30/60/100 psig |
| Surface finish: | 15µin. Ra max, 10µin Ra average surface finish (10µin. Ra max, 7µin. Ra max. 5µin. Ra max optional) |
| Materials | |
| Body: | see ordering info |
| Valve seat: | PCTFE (Vespel® optional) |
| Diaphragm: | Hastelloy® C276 |
| Inlets and Outlets: | 1/4" face seal and tube weld |
| Temperature range: | -40°F to +160°F (-40°C to +71°C) |
| Leak rate: (to atmosphere) | 1x10 ⁻⁹ mbar l/s He |
| (via seat) | 1x10 ⁻⁸ mbar l/s He |
| Flow capacity: | Cv=0.06 (Cv=0.1 option) |
| Weight: | approx. 1.35kg (depending on connections or options) |
| Supply pressure effect: | 0.2 psig rise in delivery pressure per 20 psig source pressure drop @Cv=0.06 0.4 psig rise in delivery pressure per 20 psig source pressure drop @Cv=0.1 |

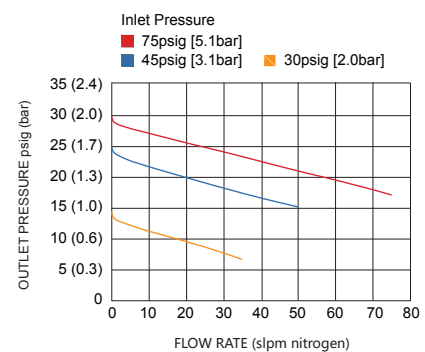

Single Stage Pressure Regulators VSR-50UC Series

Ordering Information

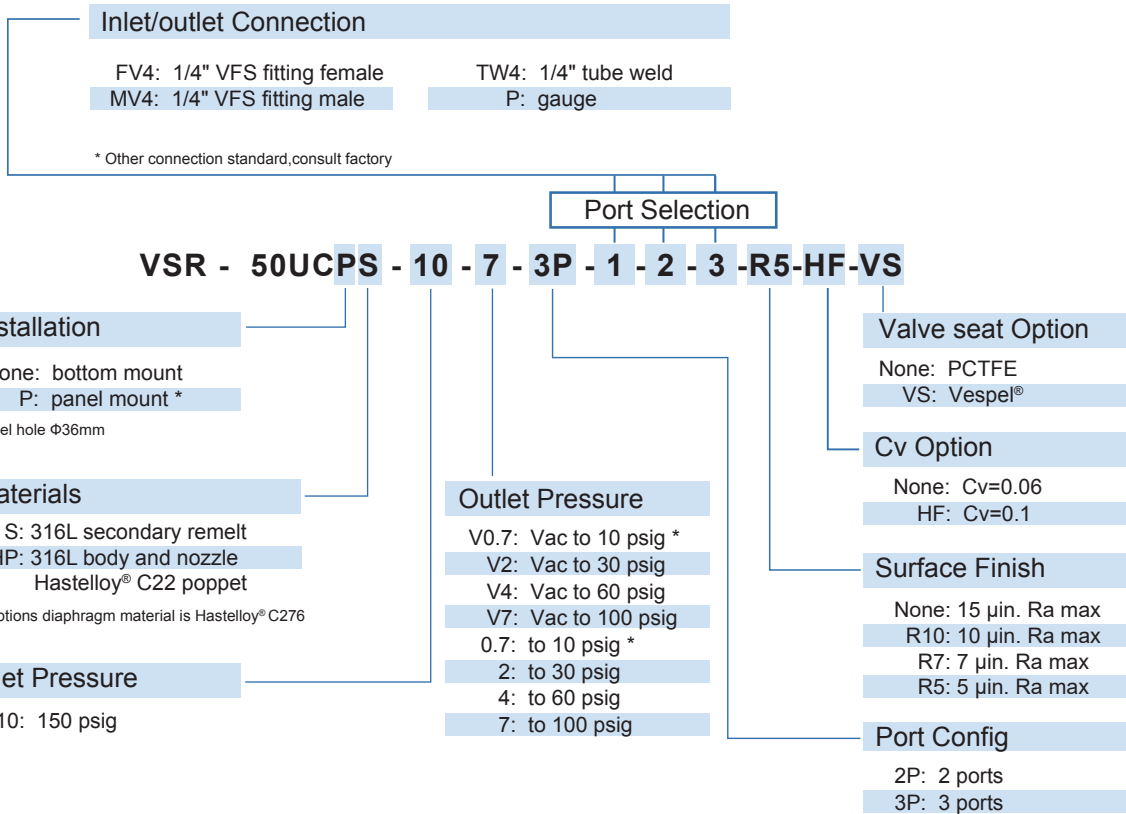
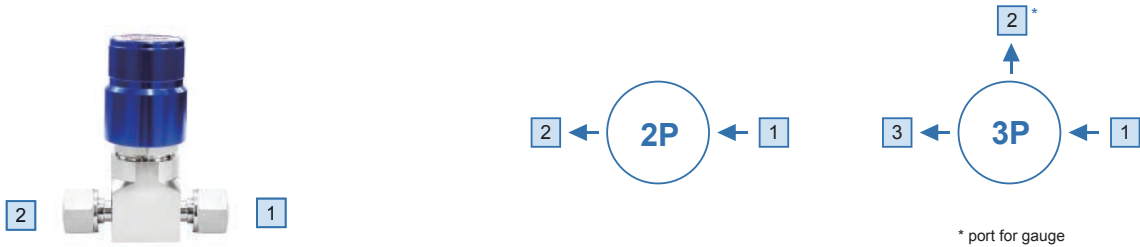

Ordering Example

VSR - 50UCS - 10 - 7 - FV4 - P - FV4
 1 - 2 - 3



Single Stage Pressure Regulators

VSR-100UB Series

Product Feature

- Single-stage pressure regulator
- 10µin. Ra surface finish (25µin. Ra optional)
- Minimized internal volume for short purge times
- All gas-wetted parts made of stainless steel SS 316L, Hastelloy C276 and PCTFE respectively
- Internal connectors for pressure gauges
- Flow capacity: to 30 slpm(standard), to 120 slpm(option)
- High control accuracy
- Metal-to-metal seal to atmosphere
- Simple outlet pressure limitation by hand-wheel
- 100% helium-leak-tested



Dimensions (mm)

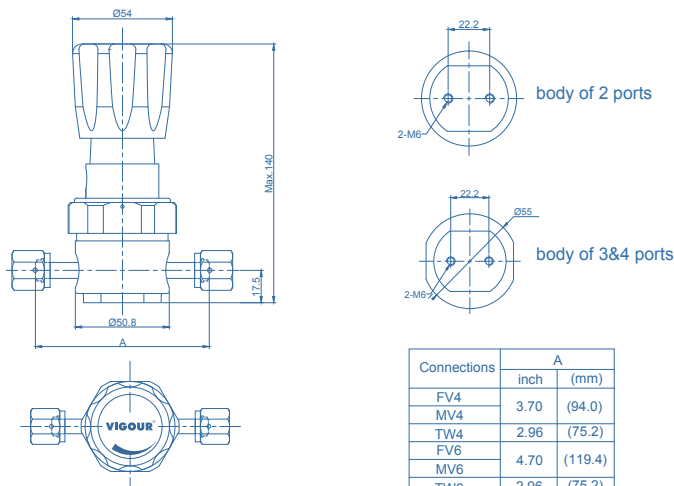

Technical Data

| | |
|----------------------------------|--|
| Type: | single-stage |
| Inlet pressure P ₁ : | max. 3500 psig |
| Outlet pressure P ₂ : | 10/30/60/100/150/720/1400/2900/3500 psig |
| Surface finish: | 10µin. Ra (25µin. Ra optional) |
| Materials | |
| Body: | see ordering info |
| Valve seat: | PCTFE (VespeI® optional) |
| Diaphragm: | Hastelloy® C276 |
| Inlets and Outlets: | 1/4" / 3/8" face seal and tube weld |
| Bonnet port: | 1/8" NPT(on panel mount option, bonnet port is not threaded) |
| Temperature range: | -40°F to +160°F (-40°C to +71°C) |
| Leak rate: (to atmosphere) | 1x10 ⁻⁹ mbar l/s He |
| (via seat) | 1x10 ⁻⁸ mbar l/s He |
| Flow capacity: | Cv=0.09 (Cv=0.15 option) |
| Weight: | approx. 1.35kg (depending on connections or options) |
| Supply pressure effect: | 0.35 psig rise in delivery pressure per 100 psig source pressure drop @Cv=0.09 0.5psig rise in delivery pressure per 100 psig source pressure drop @Cv=0.15 |

Flowchart

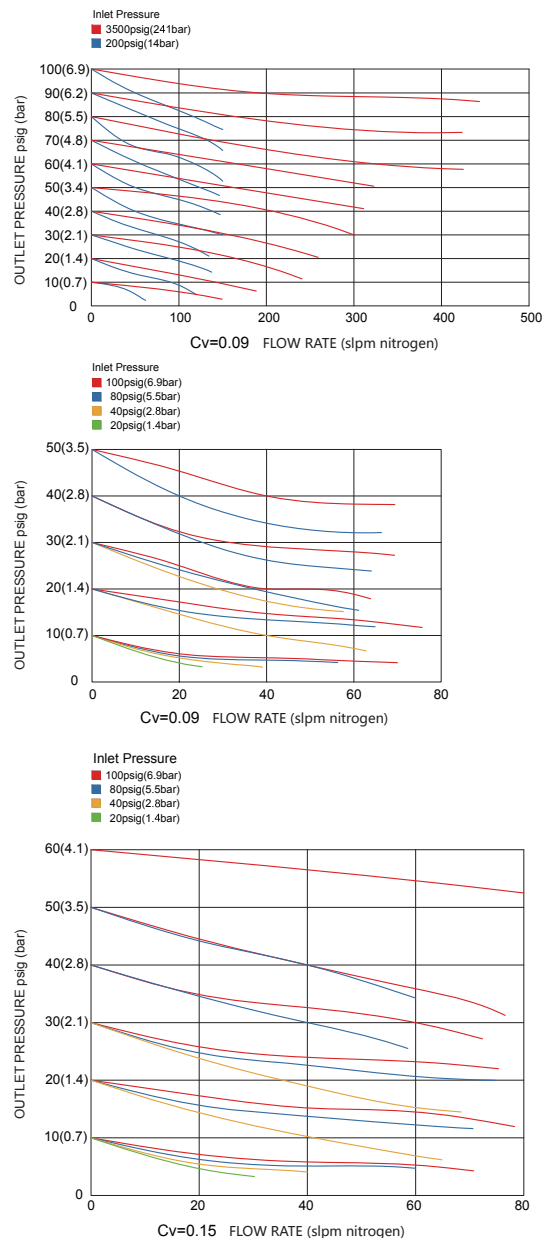

Single Stage Pressure Regulators VSR-100UB Series

Ordering Information

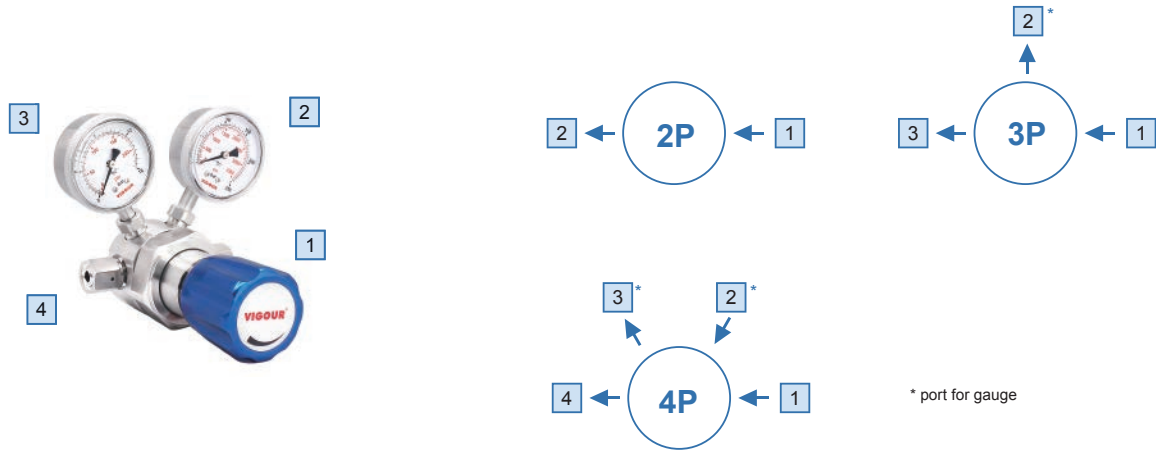

Inlet/outlet Connection

- FV4: 1/4" VFS fitting female
- MV4: 1/4" VFS fitting male
- FV6: 3/8" VFS fitting female
- MV6: 3/8" VFS fitting male
- TW4: 1/4" tube weld
- TW6: 3/8" tube weld
- P: gauge

* Other connection standard, consult factory

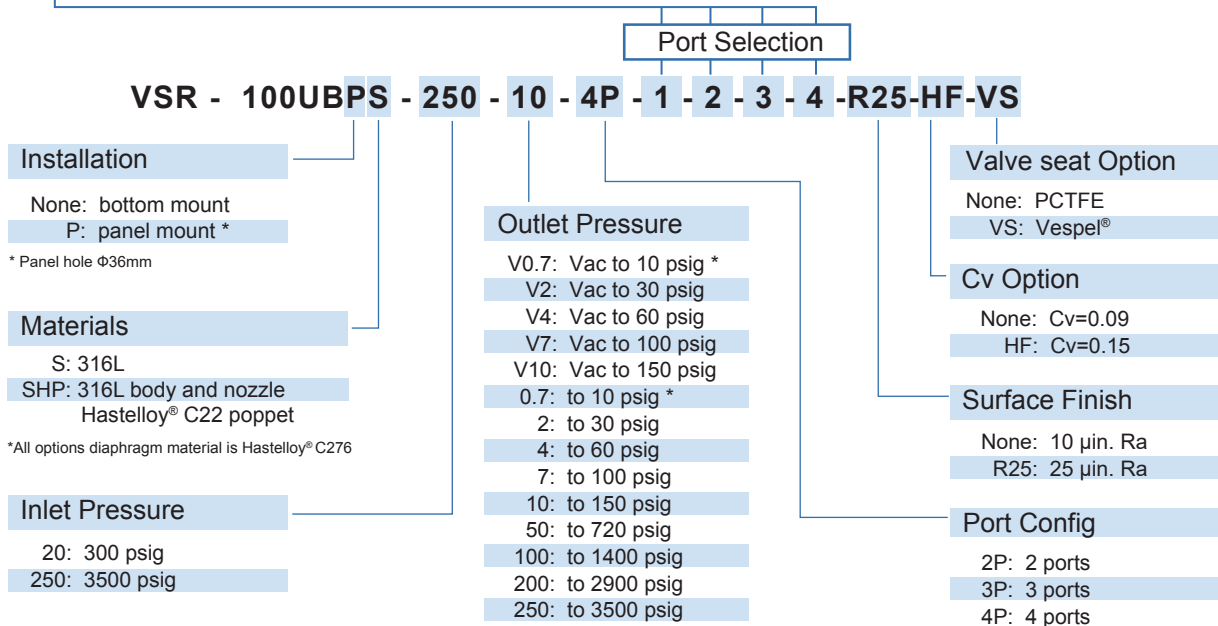

* When the outlet pressure is "V0.7" and "0.7", the inlet pressure can only be "20".

Ordering Example

VSR - 100UBS - 250 - 10 - FV4 - P - P - FV4

1 - 2 - 3 - 4



Single Stage Pressure Regulators

VSR-100UC Series

Product Feature

- Single-stage pressure regulator
- 15µin. Ra max, 10µin Ra average surface finish (10µin. Ra max, 7µin. Ra max. 5µin. Ra max optional)
- Minimized internal volume for short purge times
- All gas-wetted parts made of stainless steel SS 316L, Hastelloy C276 and PCTFE respectively
- Internal connectors for pressure gauges
- Flow capacity: to 30 slpm(standard), to 120 slpm(option)
- High control accuracy
- Metal-to-metal seal to atmosphere
- Simple outlet pressure limitation by hand-wheel
- 100% helium-leak-tested



Dimensions (mm)

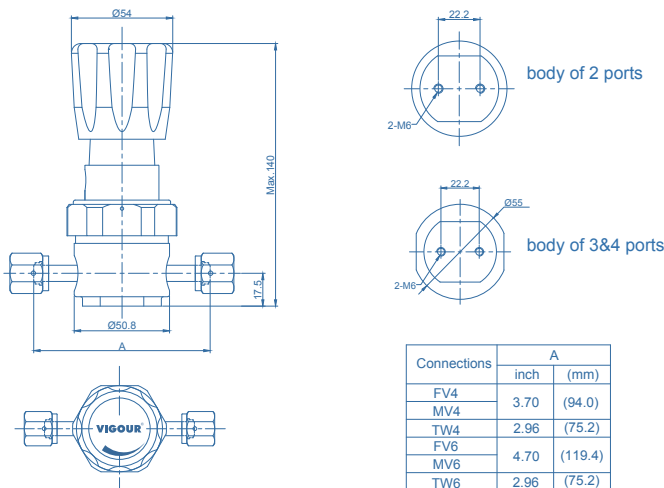

Technical Data

| | |
|----------------------------|--|
| Type: | single-stage |
| Inlet pressure P1: | max. 3500 psig |
| Outlet pressure P2: | 10/30/60/100/150/720/1400/2900/3500 psig |
| Surface finish: | 15µin. Ra max/10µin. Ra avg (10µin. Ra max, 7µin. Ra max, 5µin. Ra max optional) |
| Materials | |
| Body: | see ordering info |
| Valve seat: | PCTFE (Vespel® optional) |
| Diaphragm: | Hastelloy® C276 |
| Inlets and Outlets: | 1/4" / 3/8" face seal and tube weld |
| Bonnet port: | 1/8" NPT(on panel mount option, bonnet port is not threaded) |
| Temperature range: | -40°F to +160°F (-40°C to +71°C) |
| Leak rate: (to atmosphere) | 1x10 ⁻⁹ mbar l/s He |
| (via seat) | 1x10 ⁻⁸ mbar l/s He |
| Flow capacity: | Cv=0.09 (Cv=0.15 option) |
| Weight: | approx. 1.35kg (depending on connections or options) |
| Supply pressure effect: | 0.35 psig rise in delivery pressure per 100 psig source pressure drop @Cv=0.09 0.5psig rise in delivery pressure per 100 psig source pressure drop @Cv=0.15 |

Flowchart

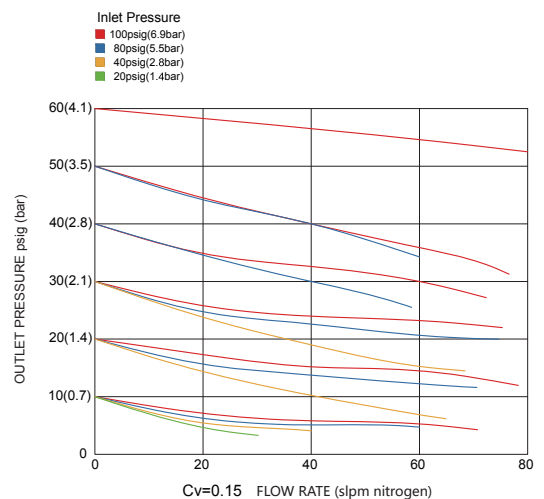
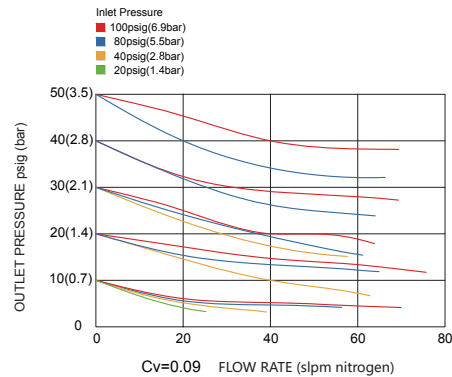
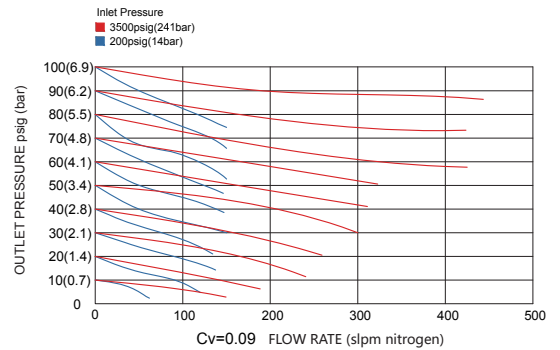

Single Stage Pressure Regulators VSR-100UC Series

Ordering Information

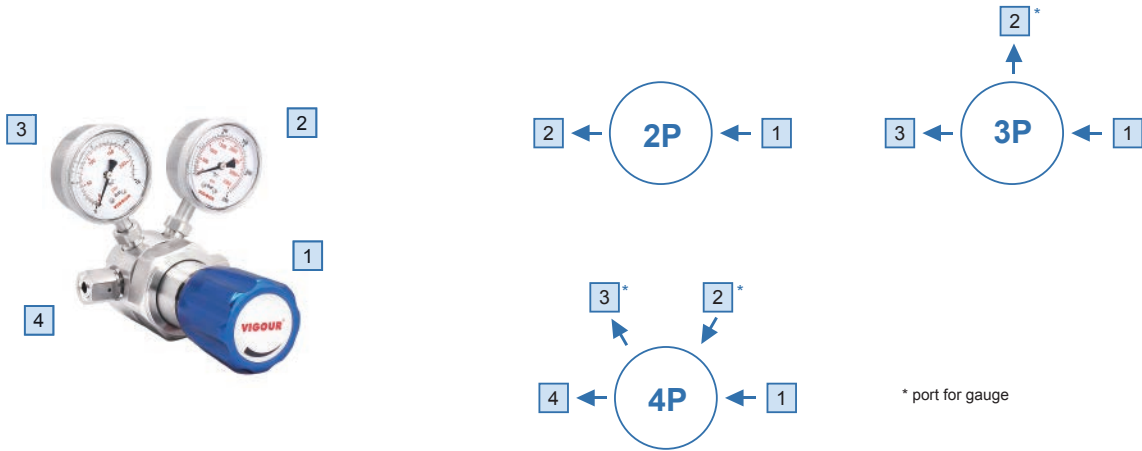

* port for gauge

Inlet/outlet Connection

FV4: 1/4" VFS fitting female
MV4: 1/4" VFS fitting male
FV6: 3/8" VFS fitting female
MV6: 3/8" VFS fitting male

TW4: 1/4" tube weld
TW6: 3/8" tube weld
P: gauge

* Other connection standard, consult factory

Port Selection

VSR - 100UCPS - 250 - 10 - 4P - 1 - 2 - 3 - 4 - R5 - HF - VS

Installation

None: bottom mount
P: panel mount

* Panel hole Φ 36mm

Materials

S: 316L secondary remelt body
316L poppet and nozzle
SH: 316L secondary remelt body
Hastelloy® C22 internals
SHP: 316L secondary remelt body
Hastelloy® C22 poppet
316L nozzle
H: Hastelloy® C22 body and internals

*All options diaphragm material is Hastelloy® C276

Inlet Pressure

20: 300 psig
250: 3500 psig

Port Config

2P: 2 ports
3P: 3 ports
4P: 4 ports

Outlet Pressure

V0.7: Vac to 10 psig *
V2: Vac to 30 psig
V4: Vac to 60 psig
V7: Vac to 100 psig
V10: Vac to 150 psig
0.7: to 10 psig *
2: to 30 psig
4: to 60 psig
7: to 100 psig
10: to 150 psig
50: to 720 psig
100: to 1400 psig
200: to 2900 psig
250: to 3500 psig

* When the outlet pressure is "V0.7" and "0.7", the inlet pressure can only be "20".

Valve seat Option

None: PCTFE
VS: VespeI®

Cv Option

None: Cv=0.09
HF: Cv=0.15

Surface Finish

None: 15 μ m. Ra max
R10: 10 μ m. Ra max
R7: 7 μ m. Ra max
R5: 5 μ m. Ra max



Ordering Example

VSR - 100UCS - 250 - 10 - 4P - FV4 - P - P - FV4
1 - 2 - 3 - 4

Single Stage Pressure Regulators

VSR-210UB Series

Product Feature

- Single-stage pressure regulator
- 10µin. Ra surface finish (25µin. Ra optional)
- Minimized internal volume for short purge times
- All gas-wetted parts made of stainless steel SS 316L, Hastelloy C276 and PCTFE respectively
- Internal connectors for pressure gauges
- Force compensation has wider flow capacity
- High control accuracy
- Metal-to-metal seal to atmosphere
- Simple outlet pressure limitation by hand-wheel
- 100% helium-leak-tested
- Tied-diaphragm design



Dimensions (mm)

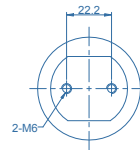
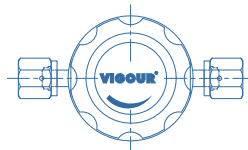
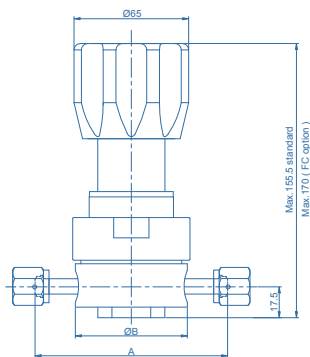

| Connections | B | A | |
|-------------|------|------|---------|
| | | inch | (mm) |
| FV4 | 50.8 | 3.70 | (94.0) |
| MV4 | | 4.00 | (101.6) |
| TW4 | | 3.46 | (87.9) |
| FV6 | 63.5 | 5.22 | (132.6) |
| MV6 | | 4.00 | (101.6) |
| TW6 | | 5.22 | (132.6) |
| FV8 | 63.5 | 4.34 | (110.2) |
| TW8 | | 4.34 | (110.2) |

Technical Data

| | |
|----------------------------|--|
| Type: | single-stage |
| Inlet pressure P1: | max. 3000 psig |
| Outlet pressure P2: | 30/60/100/150 psig |
| Surface finish: | 10µin. Ra (25µin. Ra optional) |
| Materials | |
| Body: | see ordering info |
| Valve seat: | PCTFE (Vespel® optional) |
| Diaphragm: | Hastelloy® C276 |
| Inlets and Outlets: | 1/4" / 3/8" or 1/2" face seal or tube weld |
| Bonnet port: | 1/8" NPT(F) (on panel mount option, bonnet port is not threaded) |
| Temperature range: | -40°F to +160°F (-40°C to +71°C) |
| Leak rate: (to atmosphere) | 1x10 ⁻⁹ mbar l/s He |
| (via seat) | 1x10 ⁻⁸ mbar l/s He |
| Flow capacity: | Cv=0.65, Cv=1.1 (HF optional) |
| Weight: | approx. 2.0kg |
| Supply pressure effect: | 3.5 psig rise in delivery pressure per 100 psig source pressure drop 4.2 psig rise in delivery pressure per 100 psig source pressure drop (FC option) |

Flowchart

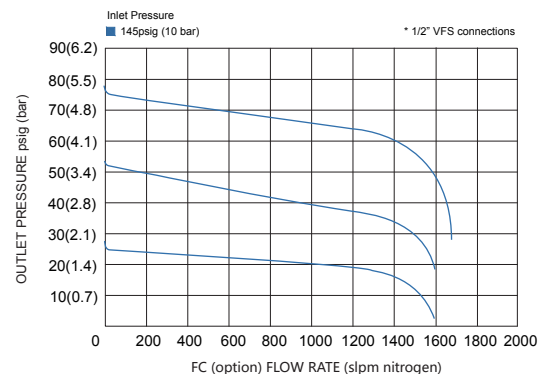
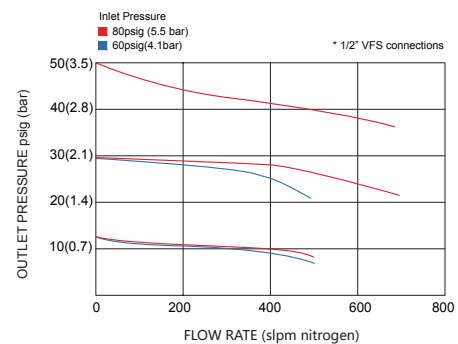

Single Stage Pressure Regulators VSR-210UB Series

Ordering Information

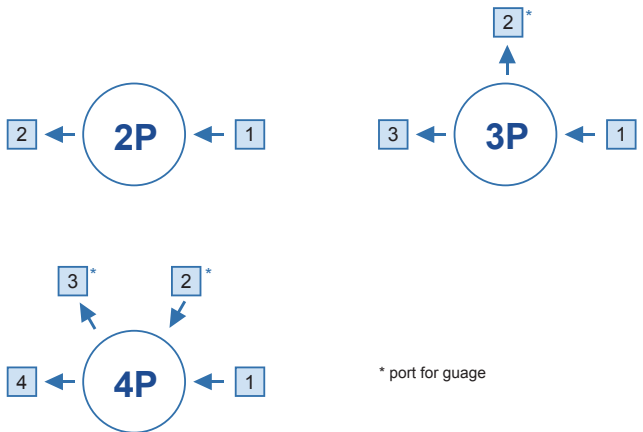

Inlet/Outlet Connection

- | | |
|------------------------------|----------------------------|
| FV4: 1/4" VFS fitting female | MV8: 1/2" VFS fitting male |
| MV4: 1/4" VFS fitting male | TW4: 1/4" tube weld |
| FV6: 3/8" VFS fitting female | TW6: 3/8" tube weld |
| MV6: 3/8" VFS fitting male | TW8: 1/2" tube weld |
| FV8: 1/2" VFS fitting female | P: gauge |

* Other connection standard, consult factory

Port Selection

VSR - 210UBPS - 117 - V4 - 4P - 1 - 2 - 3 - 4 - R25-HF-FC-VS

Installation
None: bottom mount
P: panel mount

* Panel hole Ø37mm

Materials
S: 316L
SHP: 316L body
Hastelloy® C22 poppet

*All options diaphragm material is Hastelloy® C276

Inlet Pressure
20: 300 psig
117: 1700 psig (standard)
200: 3000 psig*

* Not available with outlet pressure:
V2 / V4 / 2 / 4

Port Config
2P: 2 ports
3P: 3 ports
4P: 4 ports

Outlet Pressure
V2: Vac to 30 psig
V4: Vac to 60 psig
V7: Vac to 100 psig
V10: Vac to 150 psig
2: to 30 psig
4: to 60 psig
7: to 100 psig
10: to 150 psig
P17: Preset to 250 psig*

* 250 psig outlet pressure preset at 800 psig (55 bar) inlet pressure.

Valve seat Option
None: PCTFE
VS: Vespel®

Option
FC: Force compensation
* Force compensation feature inlet pressure Max. 300 psig
* FC option is available with connection size 1/2 inch
* Not available with outlet pressure:
V2 / V4 / 2 / 4

Cv Option
None: Cv=0.65
HF: Cv=1.1

Surface Finish
None: 10 µin. Ra
R25: 25 µin. Ra

Ordering Example

VSR - 210UBS - 117 - V4 - 2P - MV4 - MV4

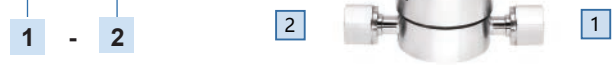

Single Stage Pressure Regulators

VSR-210UC Series

Product Feature

- Single-stage pressure regulator
- 15µin. Ra max, 10µin. Ra average surface finish (10µin. Ra max, 7µin. Ra max, 5µin. Ra max optional)
- Minimized internal volume for short purge times
- All gas-wetted parts made of stainless steel SS 316L, Hastelloy C276 and PCTFE respectively
- Internal connectors for pressure gauges
- Force compensation has wider flow capacity
- High control accuracy
- Metal-to-metal seal to atmosphere
- Simple outlet pressure limitation by hand-wheel
- 100% helium-leak-tested
- Tied-diaphragm design



Dimensions (mm)

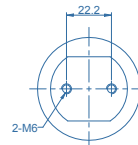
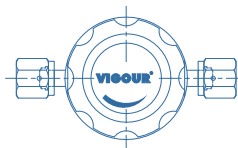
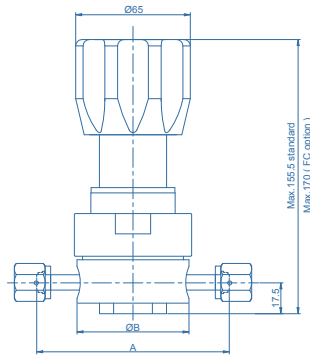

| Connections | B | A | |
|-------------|------|------|---------|
| | | inch | (mm) |
| FV4 | 50.8 | 3.70 | (94.0) |
| MV4 | | 4.00 | (101.6) |
| TW4 | | 3.46 | (87.9) |
| FV6 | 63.5 | 5.22 | (132.6) |
| MV6 | | 4.00 | (101.6) |
| TW6 | | 5.22 | (132.6) |
| FV8 | 63.5 | 4.34 | (110.2) |
| MV8 | | 6.26 | (159.0) |
| TW8 | | 5.00 | (127.0) |

Technical Data

| | |
|----------------------------|--|
| Type: | single-stage |
| Inlet pressure P1: | max. 3000 psig |
| Outlet pressure P2: | 30/60/100/150 psig |
| Surface finish: | 15µin. Ra max / 10µin. Ra avg (10µin. Ra max., 7µin. Ra max., 5µin. Ra max optional) |
| Materials | |
| Body: | see ordering info |
| Valve seat: | PCTFE (Vespel® optional) |
| Diaphragm: | Hastelloy® C276 |
| Inlets and Outlets: | 1/4" / 3/8" / 1/2" or 3/4" face seal or tube weld |
| Bonnet port: | 1/8" NPT(F) (on panel mount option, bonnet port is not threaded) |
| Temperature range: | -40°F to +160°F (-40°C to +71°C) |
| Leak rate: (to atmosphere) | 1x10 ⁻⁹ mbar l/s He |
| (via seat) | 1x10 ⁻⁹ mbar l/s He |
| Flow capacity: | Cv=0.65, Cv=1.1 (HF optional) |
| Weight: | approx. 2.0kg |
| Supply pressure effect: | 3.5 psig rise in delivery pressure per 100 psig source pressure drop 4.2 psig rise in delivery pressure per 100 psig source pressure drop (FC option) |

Flowchart

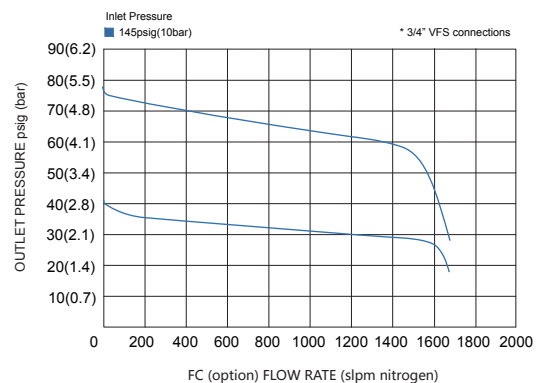
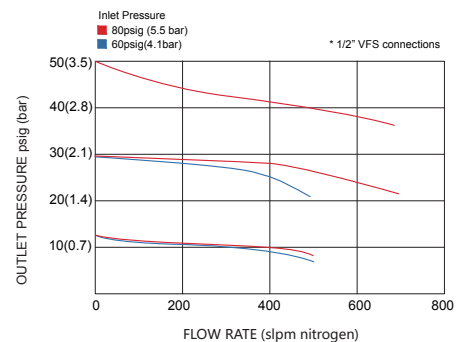

Single Stage Pressure Regulators VSR-210UC Series

Ordering Information

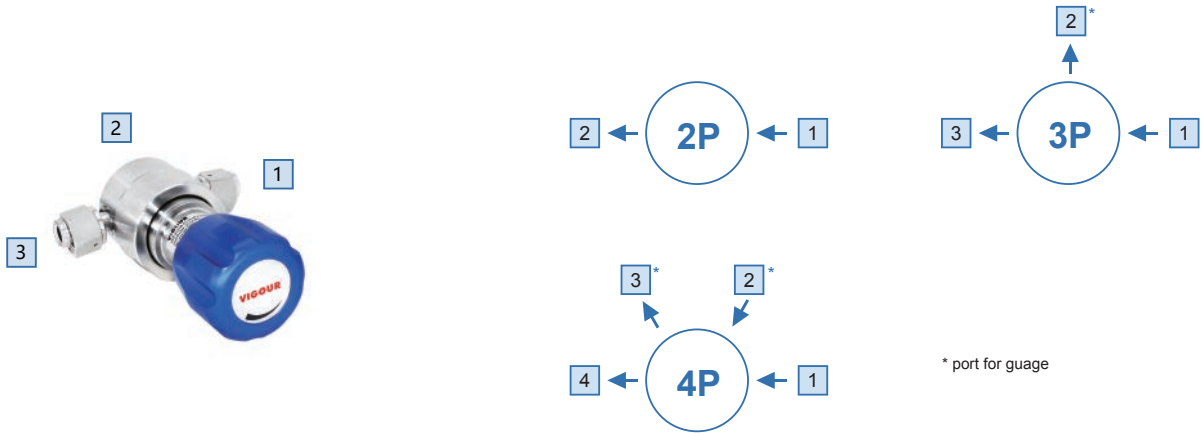

Inlet/outlet Connection

| | | |
|------------------------------|-------------------------------|----------------------|
| FV4: 1/4" VFS fitting female | MV8: 1/2" VFS fitting male | TW8: 1/2" tube weld |
| MV4: 1/4" VFS fitting male | FV12: 3/4" VFS fitting female | TW12: 3/4" tube weld |
| FV6: 3/8" VFS fitting female | MV12: 3/4" VFS fitting male | P: gauge |
| MV6: 3/8" VFS fitting male | TW4: 1/4" tube weld | |
| FV8: 1/2" VFS fitting female | TW6: 3/8" tube weld | |

* Other connection standard, consult factory

Port Selection

VSR - 210UCPS-117-V4-4P-1-2-3-4-R5-HF-FC-VS

Installation

None: bottom mount
P: panel mount

* Panel hole Φ 37mm

Materials

S: 316L secondary remelt body
316L poppet and nozzle
SH: 316L secondary remelt body
Hastelloy® C22 internals
SHP: 316L secondary remelt body
Hastelloy® C22 poppet
316L nozzle

*All options diaphragm material is Hastelloy® C276

Inlet Pressure

20: 300 psig
117: 1700 psig (standard)
200: 3000 psig*

* Not available with outlet pressure:
V2 / V4 / 2 / 4

Port Config

2P: 2 ports
3P: 3 ports
4P: 4 ports

Outlet Pressure

V2: Vac to 30 psig
V4: Vac to 60 psig
V7: Vac to 100 psig
V10: Vac to 150 psig
2: to 30 psig
4: to 60 psig
7: to 100 psig
10: to 150 psig
P17: Preset to 250 psig*

* 250 psig outlet pressure preset
at 800 psig (55 bar) inlet pressure.

Valve seat Option

None: PCTFE
VS: Vespel®

Option

FC: Force compensation

* Force compensation feature inlet
pressure Max. 300 psig

* FC option is available with
connection size 1/2 or 3/4 inch

* Not available with outlet pressure:
V2 / V4 / 2 / 4

* connection size 3/4 inch
Max. 2400 psig

Cv Option

None: Cv=0.65
HF: Cv=1.1

Surface Finish

None: 15 μ m. Ra max
R10: 10 μ m. Ra max
R7: 7 μ m. Ra max
R5: 5 μ m. Ra max

Ordering Example

VSR - 210UCS - 117 - V4 - 2P - MV4 - FV4

1 - 2



Single Stage Pressure Regulators

VSR-410UB Series

Product Feature

- Single-stage pressure regulator
- 10µin. Ra surface finish (25µin. Ra optional)
- Minimized internal volume for short purge times
- All gas-wetted parts made of stainless steel SS 316L, Hastelloy C276 and PCTFE respectively
- Internal connectors for pressure gauges
- High inlet pressure type: Max. 3000 psig
- High control accuracy
- Metal-to-metal seal to atmosphere
- Simple outlet pressure limitation by hand-wheel
- 100% helium-leak-tested
- Tied-diaphragm design
- Sub-atmospheric pressure delivery option



Dimensions (mm)

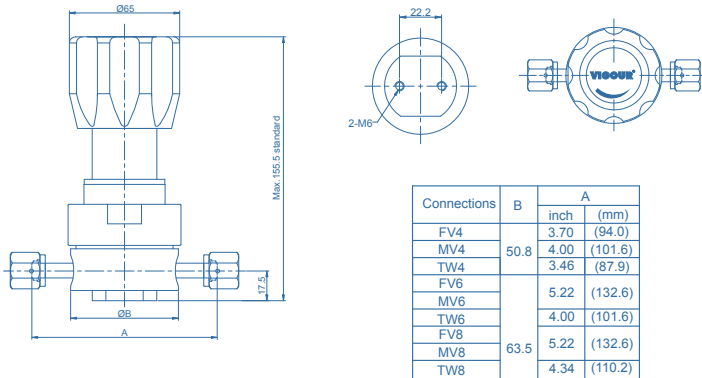

Technical Data

| | |
|----------------------------|--|
| Type: | single-stage |
| Inlet pressure P1: | max. 3000 psig |
| Outlet pressure P2: | -12.5~30/30/60/100/150 psig |
| Surface finish: | 10µin. Ra (25µin. Ra optional) |
| Materials | |
| Body: | see ordering info |
| Valve seat: | PCTFE (Vespe ^l ® optional) |
| Diaphragm: | Hastelloy [®] C276 |
| Inlets and Outlets: | 1/4" / 3/8" or 1/2" face seal or tube weld |
| Bonnet port: | 1/8" NPT(F) (on panel mount option, bonnet port is not threaded) |
| Temperature range: | -40°F to +160°F (-40°C to +71°C) |
| Leak rate: (to atmosphere) | 1x10 ⁻⁹ mbar l/s He |
| (via seat) | 1x10 ⁻⁸ mbar l/s He |
| Flow capacity: | Cv=0.45 |
| Weight: | approx. 2.0kg |
| Supply pressure effect: | 1.6 psig rise in delivery pressure per 100 psig source pressure drop |

Flowchart

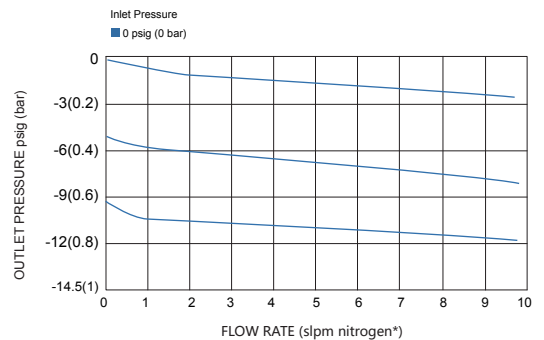
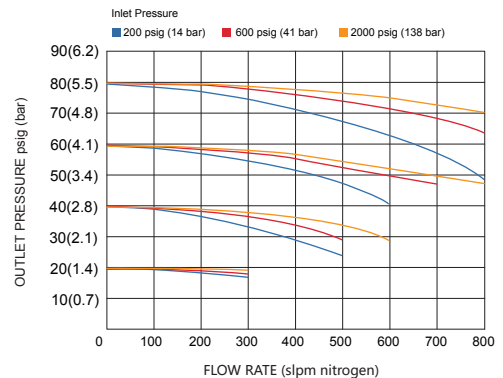
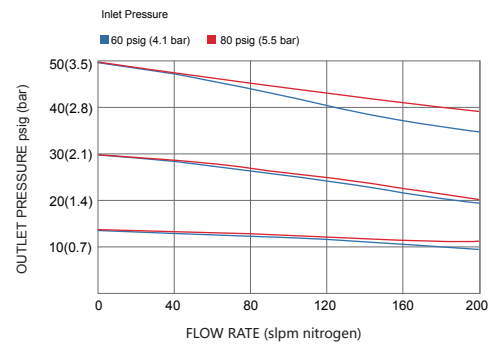

* The volumetric flow rate under normal conditions (0°C, 1 atm) when N₂ gas is flowing.

Single Stage Pressure Regulators VSR-410UB Series

Ordering Information

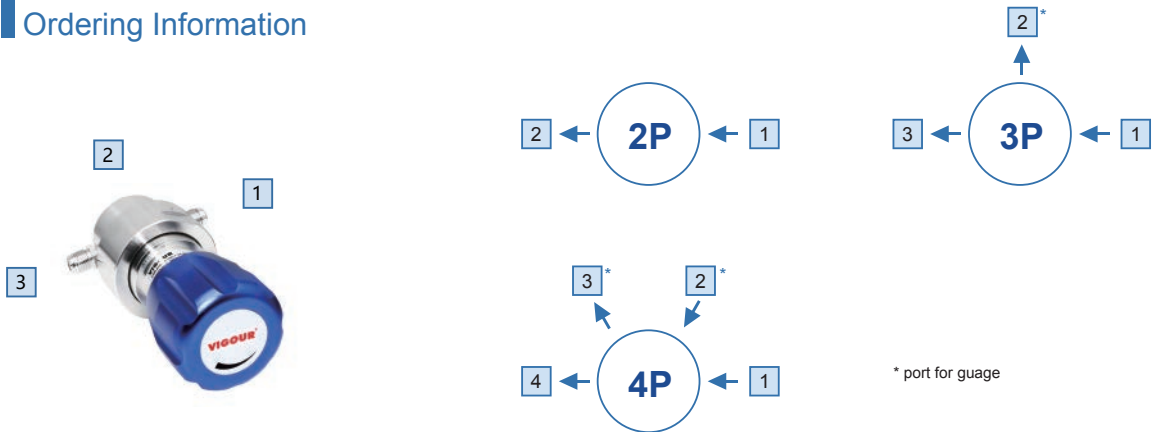

Inlet/Outlet Connection

- | | |
|------------------------------|----------------------------|
| FV4: 1/4" VFS fitting female | MV8: 1/2" VFS fitting male |
| MV4: 1/4" VFS fitting male | TW4: 1/4" tube weld |
| FV6: 3/8" VFS fitting female | TW6: 3/8" tube weld |
| MV6: 3/8" VFS fitting male | TW8: 1/2" tube weld |
| FV8: 1/2" VFS fitting female | P: gauge |

* Other connection standard, consult factory

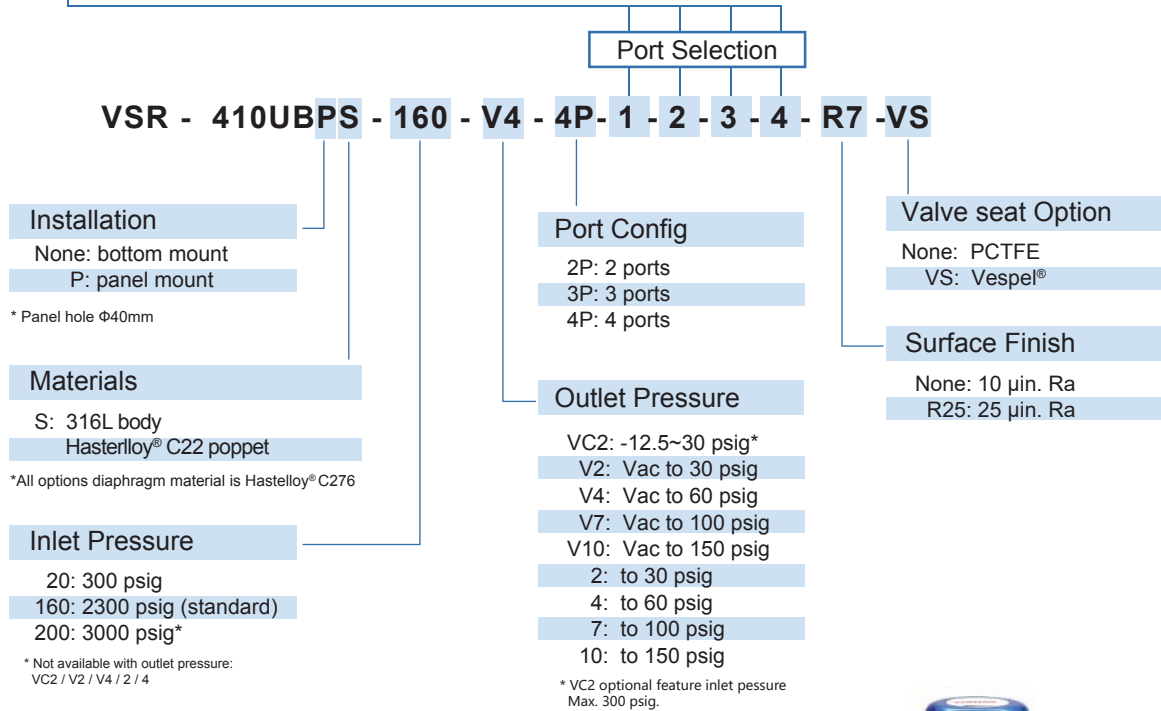

Ordering Example

VSR - 410UBS - 160 - V4 - 2P - MV4 - MV4
1 - 2



Single Stage Pressure Regulators

VSR-410UC Series

Product Feature

- Single-stage pressure regulator
- 15µin. Ra max, 10µin. Ra average surface finish (10µin. Ra max, 7µin. Ra max, 5µin. Ra max optional)
- Minimized internal volume for short purge times
- All gas-wetted parts made of stainless steel SS 316L, Hastelloy C276 and PCTFE respectively
- Internal connectors for pressure gauges
- High inlet pressure type: Max. 3000 psig
- High control accuracy
- Metal-to-metal seal to atmosphere
- Simple outlet pressure limitation by hand-wheel
- 100% helium-leak-tested
- Tied-diaphragm design
- Sub-atmospheric pressure delivery option



Dimensions (mm)

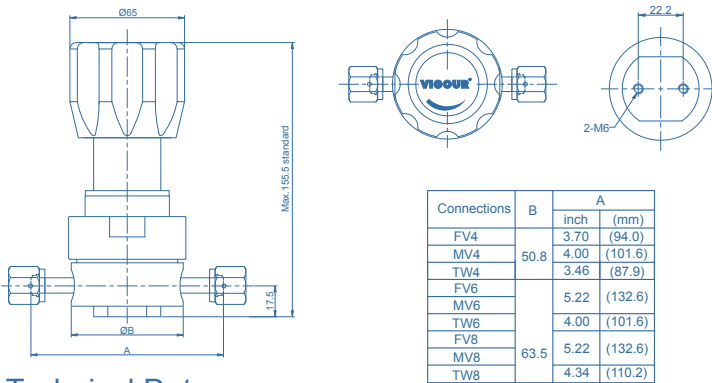

Technical Data

| | |
|----------------------------------|--|
| Type: | single-stage |
| Inlet pressure P ₁ : | max. 3000 psig |
| Outlet pressure P ₂ : | -12.5~30/30/60/100/150 psig |
| Surface finish: | 15µin. Ra max / 10µin. Ra avg (10µin. Ra max., 7µin. Ra max., 5µin. Ra max optional) |
| Materials | |
| Body: | see ordering info |
| Valve seat: | PCTFE (Vespel® optional) |
| Diaphragm: | Hastelloy® C276 |
| Inlets and Outlets: | 1/4" / 3/8" / 1/2" or 3/4" face seal or tube weld |
| Bonnet port: | 1/8" NPT(F) (on panel mount option, bonnet port is not threaded) |
| Temperature range: | -40°F to +160°F (-40°C to +71°C) |
| Leak rate: (to atmosphere) | 1x10 ⁻⁹ mbar l/s He |
| (via seat) | 1x10 ⁻⁸ mbar l/s He |
| Flow capacity: | Cv=0.45 |
| Weight: | approx. 2.0kg |
| Supply pressure effect: | 1.6 psig rise in delivery pressure per 100 psig source pressure drop |

Flowchart

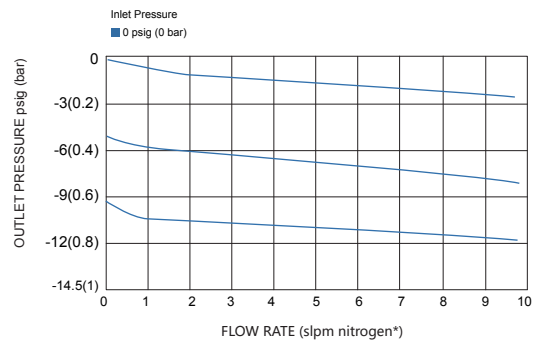
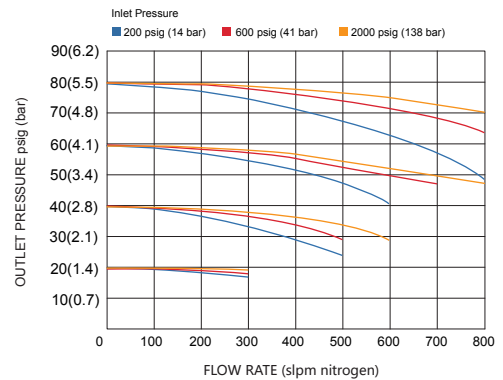
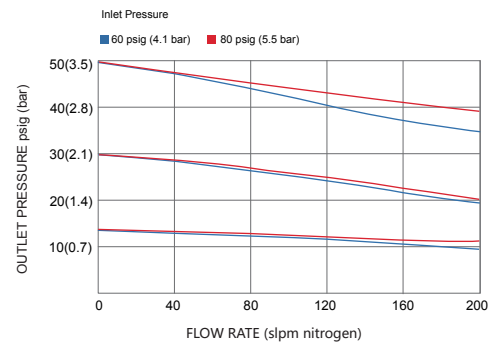

* The volumetric flow rate under normal conditions (0°C, 1 atm) when N₂ gas is flowing.

Single Stage Pressure Regulators VSR-410UC Series

Ordering Information

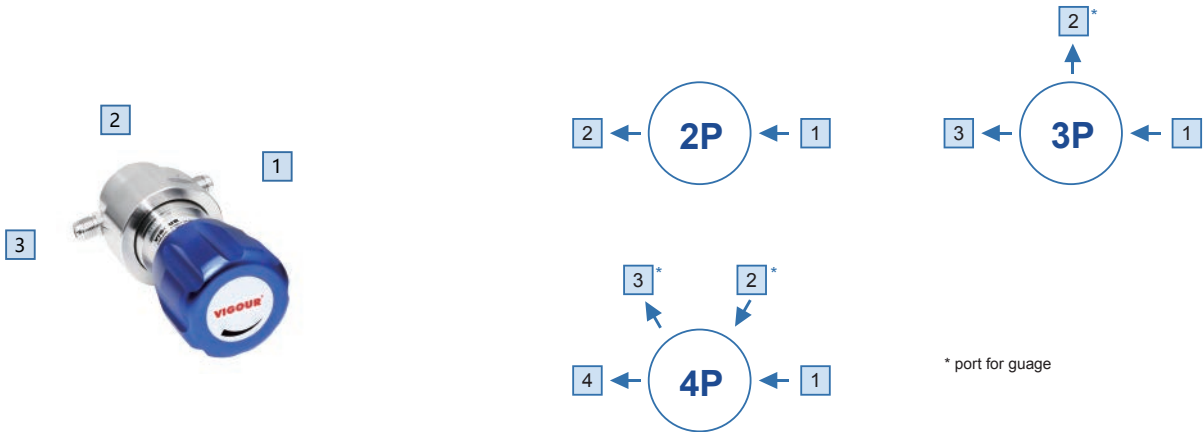

Inlet/outlet Connection

FV4: 1/4" VFS fitting female

MV4: 1/4" VFS fitting male

FV6: 3/8" VFS fitting female

MV6: 3/8" VFS fitting male

FV8: 1/2" VFS fitting female

MV8: 1/2" VFS fitting male

TW4: 1/4" tube weld

TW6: 3/8" tube weld

TW8: 1/2" tube weld

P: gauge

* Other connection standard, consult factory

Port Selection

VSR - 410UCPS - 117 - V4 - 4P- 1 - 2 - 3 - 4 - R5 -VS

Installation

None: bottom mount

P: panel mount

* Panel hole Φ 40mm

Materials

S: 316L secondary remelt body

Hastelloy® C22 poppet

316L nozzle

SH: 316L secondary remelt body

Hastelloy® C22 internals

*All options diaphragm material is Hastelloy® C276

Inlet Pressure

20: 300 psig

160: 2300 psig (standard)

200: 3000 psig*

* Not available with outlet pressure:
VC2 / V2 / V4 / 2 / 4

Port Config

2P: 2 ports

3P: 3 ports

4P: 4 ports

Outlet Pressure

VC2: -12.5~30 psig*

V2: Vac to 30 psig

V4: Vac to 60 psig

V7: Vac to 100 psig

V10: Vac to 150 psig

2: to 30 psig

4: to 60 psig

7: to 100 psig

10: to 150 psig

* VC2 optional feature inlet pressure
Max. 300 psig.

Valve seat Option

None: PCTFE

VS: Vespel®

Surface Finish

None: 15 μ m. Ra max

R10: 10 μ m. Ra max

R7: 7 μ m. Ra max

R5: 5 μ m. Ra max

Ordering Example

VSR - 410UCS - 160 - V4 - 2P - MV4 - FV4
1 - 2



Single Stage Pressure Regulators

VSR-510UB Series

Product Feature

- Single-stage pressure regulator
- 10µin. Ra surface finish (25µin. Ra optional)
- Minimized internal volume for short purge times
- All gas-wetted parts made of stainless steel SS 316L, Hastelloy C276 and PCTFE respectively
- Internal connectors for pressure gauges
- Flow capacity: to 30 slpm(standard), to 120 slpm(option)
- High control accuracy
- Metal-to-metal seal to atmosphere
- Simple outlet pressure limitation by hand-wheel
- 100% helium-leak-tested
- Tied-diaphragm design



Dimensions (mm)

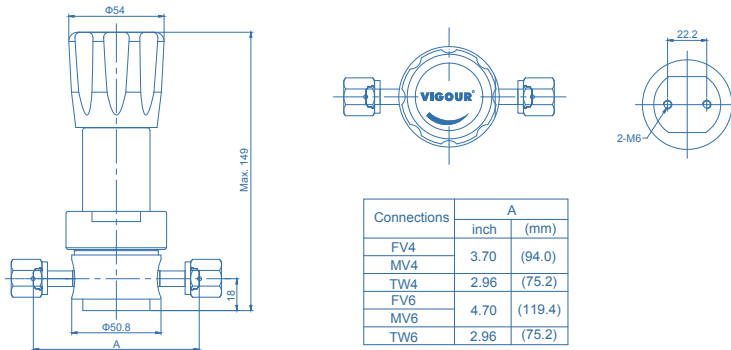

Technical Data

| | |
|----------------------------|--|
| Type: | single-stage |
| Inlet pressure P1: | max. 3500 psig |
| Outlet pressure P2: | 10/30/60/100/150 psig |
| Surface finish: | 10µin. Ra (25µin. Ra optional) |
| Materials | |
| Body: | see ordering info |
| Valve seat: | PCTFE (VespeI® optional) |
| Diaphragm: | Hastelloy® C276 |
| Inlets and Outlets: | 1/4" / 3/8" face seal and tube weld |
| Bonnet port: | 1/8" NPT(on panel mount option, bonnet port is not threaded) |
| Temperature range: | -40°F to +160°F (-40°C to +71°C) |
| Leak rate: (to atmosphere) | 1x10 ⁻⁹ mbar l/s He |
| (via seat) | 1x10 ⁻⁸ mbar l/s He |
| Flow capacity: | Cv=0.09 (Cv=0.15 option) |
| Weight: | approx. 1.35kg (depending on connections or options) |
| Supply pressure effect: | 0.35 psig rise in delivery pressure per 100 psig source pressure drop @Cv=0.09 0.5psig rise in delivery pressure per 100 psig source pressure drop @Cv=0.15 |

Flowchart

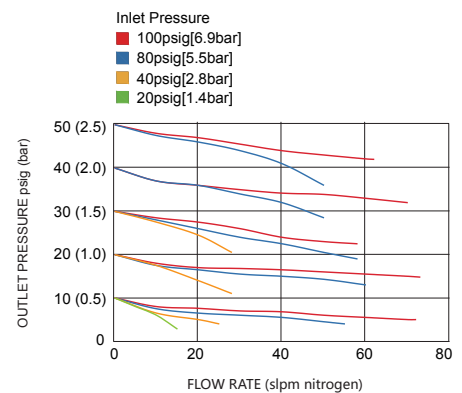
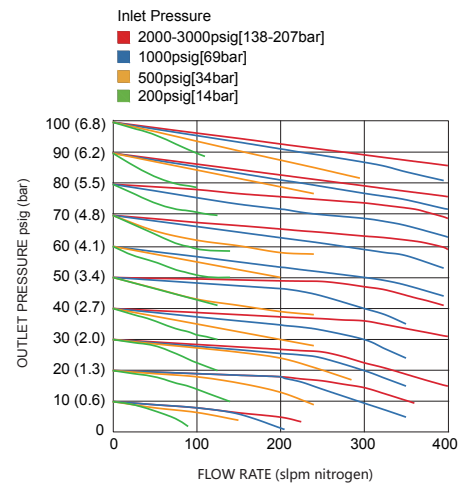

Single Stage Pressure Regulators VSR-510UB Series

Ordering Information

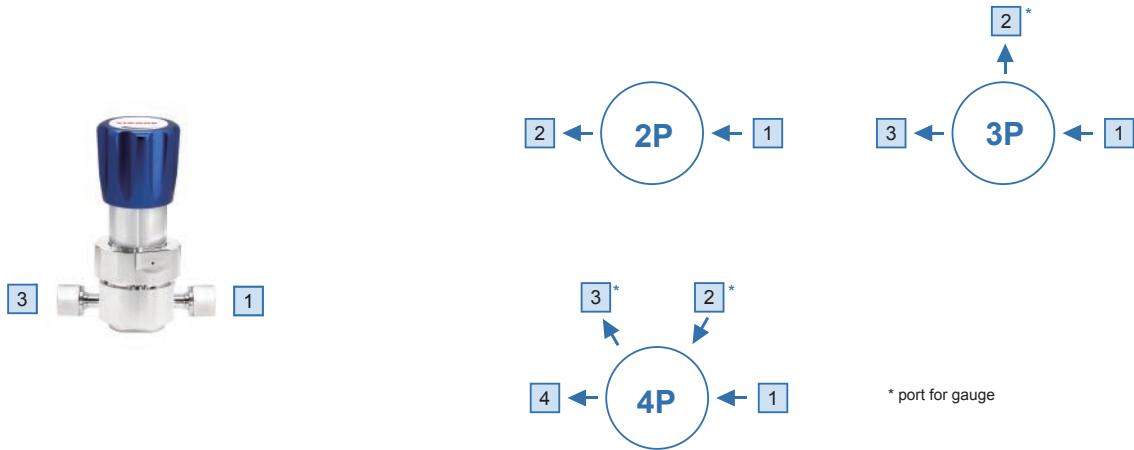

Inlet/outlet Connection

- FV4: 1/4" VFS fitting female
- MV4: 1/4" VFS fitting male
- FV6: 3/8" VFS fitting female
- MV6: 3/8" VFS fitting male
- TW4: 1/4" tube weld
- TW6: 3/8" tube weld
- P: gauge

* Other connection standard, consult factory

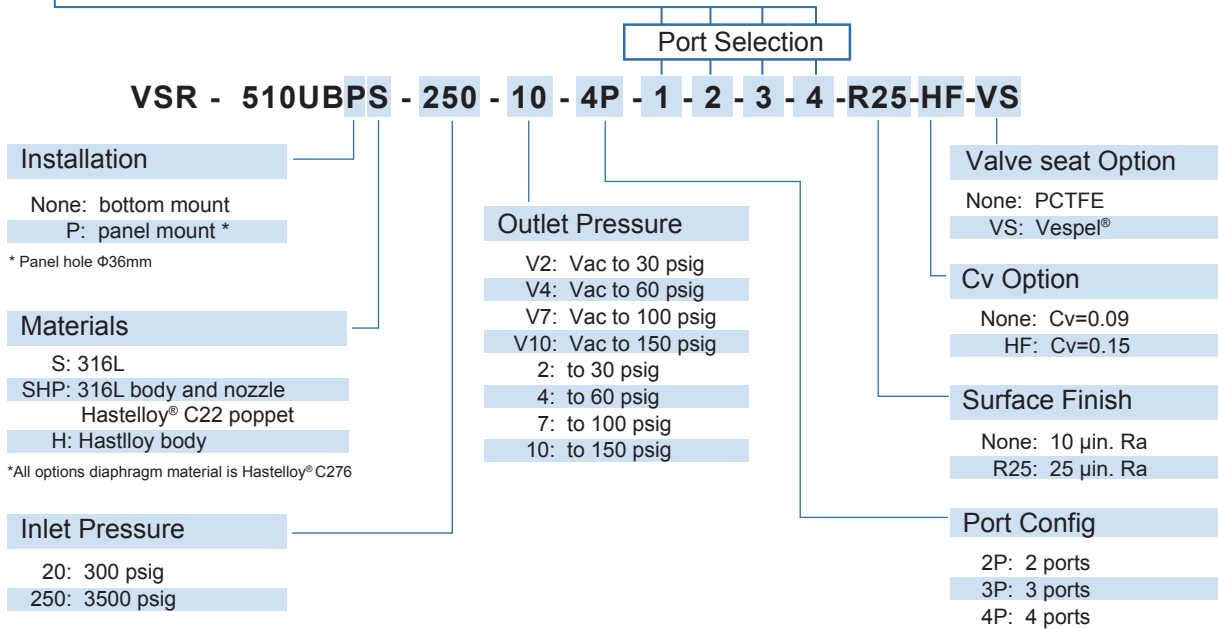

Ordering Example

VSR - 510UBS - 250 - 10 - FV4 - P - P - FV4

1 - 2 - 3 - 4



Single Stage Pressure Regulators

VSR-510UC Series

Product Feature

- Single-stage pressure regulator
- 15µin. Ra max, 10µin Ra average surface finish (10µin. Ra max, 7µin. Ra max. 5µin. Ra max optional)
- Minimized internal volume for short purge times
- All gas-wetted parts made of stainless steel SS 316L, Hastelloy C276 and PCTFE respectively
- Internal connectors for pressure gauges
- Flow capacity: to 30 slpm(standard), to 120 slpm(option)
- High control accuracy
- Metal-to-metal seal to atmosphere
- Simple outlet pressure limitation by hand-wheel
- 100% helium-leak-tested
- Tied-diaphragm design



Dimensions (mm)

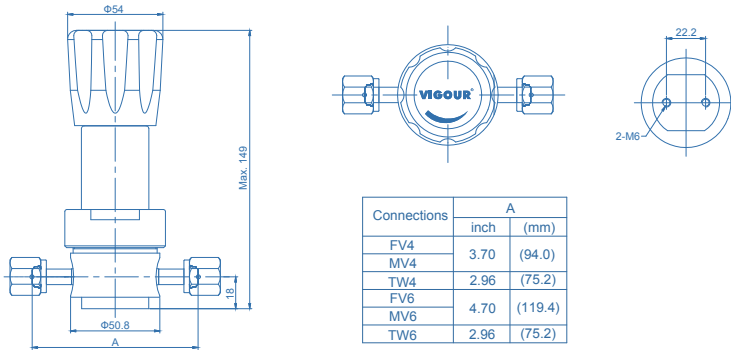

Technical Data

| | |
|----------------------------|--|
| Type: | single-stage |
| Inlet pressure P1: | max. 3500 psig |
| Outlet pressure P2: | 10/30/60/100/150 psig |
| Surface finish: | 15µin. Ra max, 10µin Ra average surface finish (10µin. Ra max, 7µin. Ra max. 5µin. Ra max optional) |
| Materials | |
| Body: | see ordering info |
| Valve seat: | PCTFE (Vespe® optional) |
| Diaphragm: | Hastelloy® C276 |
| Inlets and Outlets: | 1/4" / 3/8" face seal and tube weld |
| Bonnet port: | 1/8" NPT(on panel mount option, bonnet port is not threaded) |
| Temperature range: | -40°F to +160°F (-40°C to +71°C) |
| Leak rate: (to atmosphere) | 1x10 ⁻⁹ mbar l/s He |
| (via seat) | 1x10 ⁻⁸ mbar l/s He |
| Flow capacity: | Cv=0.09 (Cv=0.15 option) |
| Weight: | approx. 1.35kg (depending on connections or options) |
| Supply pressure effect: | 0.35 psig rise in delivery pressure per 100 psig source pressure drop @Cv=0.09 0.5psig rise in delivery pressure per 100 psig source pressure drop @Cv=0.15 |

Flowchart

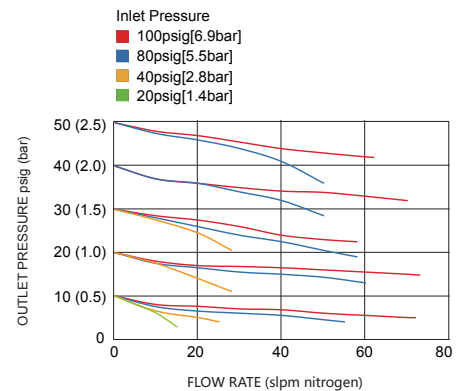
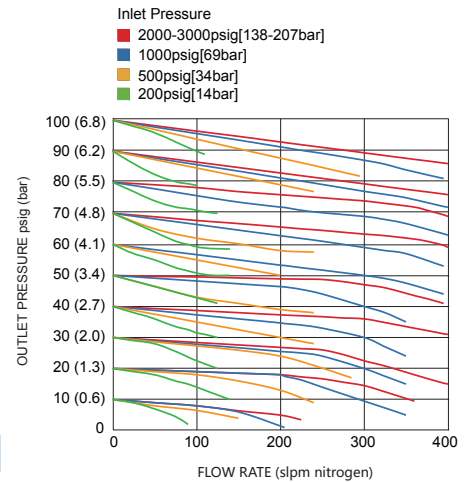

Single Stage Pressure Regulators VSR-510UC Series

Ordering Information

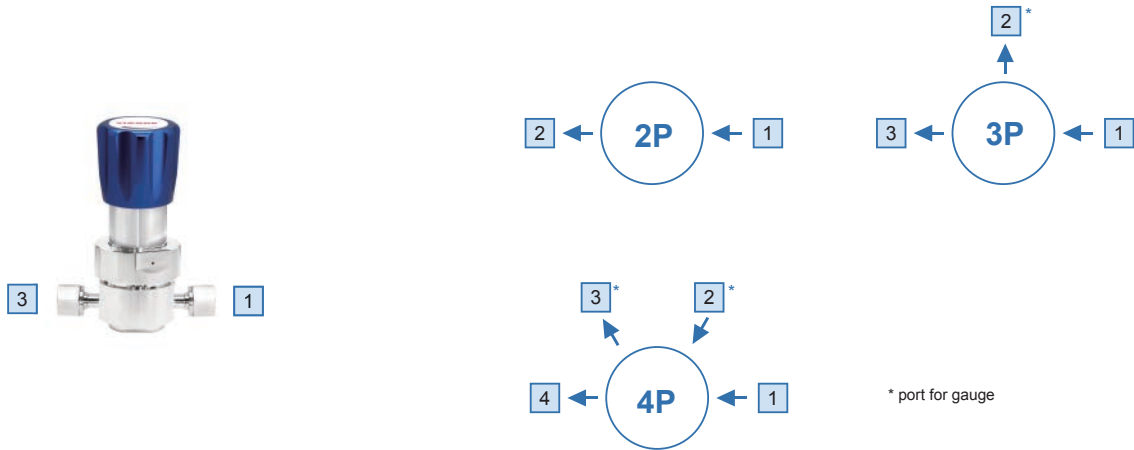

Inlet/outlet Connection

- FV4: 1/4" VFS fitting female
- MV4: 1/4" VFS fitting male
- FV6: 3/8" VFS fitting female
- MV6: 3/8" VFS fitting male
- TW4: 1/4" tube weld
- TW6: 3/8" tube weld
- P: gauge

* Other connection standard, consult factory

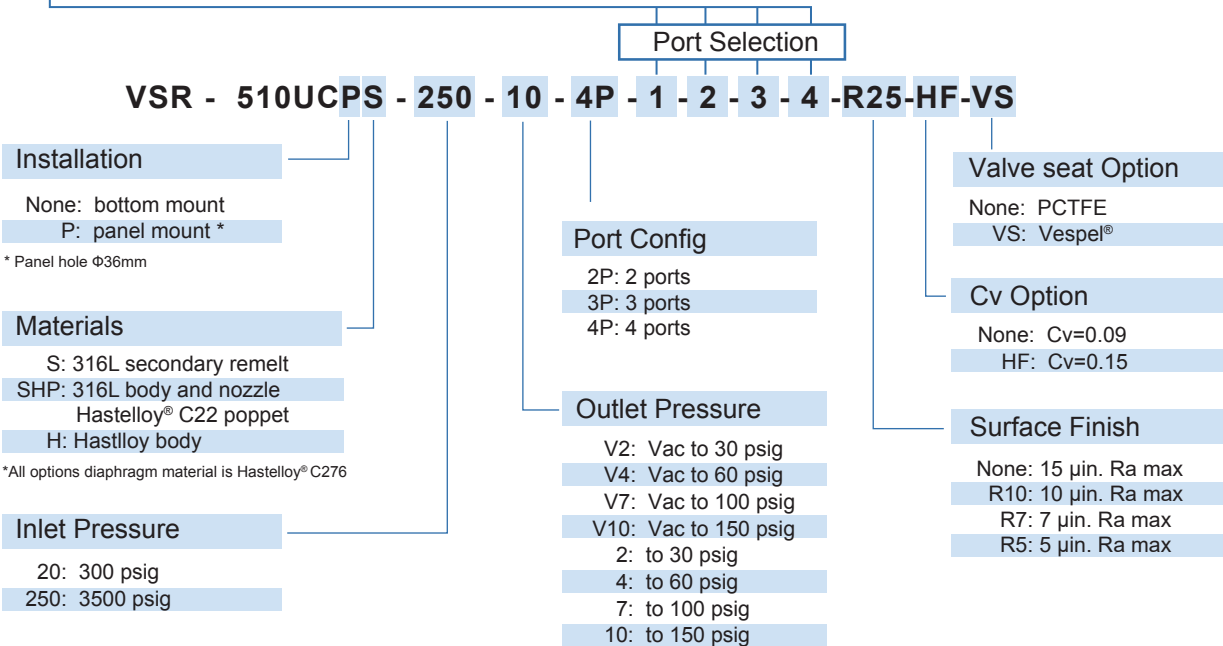

Ordering Example

VSR - 510UCS - 250 - 10 - FV4 - P - P - FV4

1 - 2 - 3 - 4



Single Stage Pressure Regulators

VSR-610UB Series

Product Feature

- Single-stage pressure regulator
- 10µin. Ra surface finish (25µin. Ra optional)
- Minimized internal volume for short purge times
- All gas-wetted parts made of stainless steel SS 316L, Hastelloy C276 and PCTFE respectively
- Internal connectors for pressure gauges
- Flow capacity: to 100 slpm
- High control accuracy
- Metal-to-metal seal to atmosphere
- Simple outlet pressure limitation by hand-wheel
- 100% helium-leak-tested



Dimensions (mm)

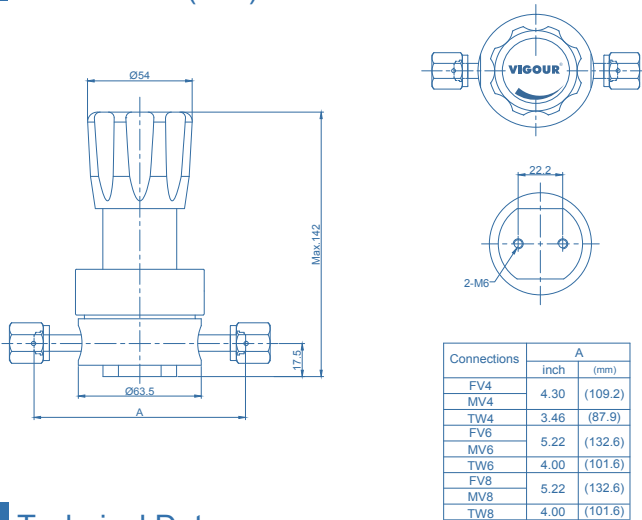

Technical Data

| | |
|----------------------------|---|
| Type: | single-stage |
| Inlet pressure P1: | max. 3500 psig |
| Outlet pressure P2: | 10/30/60/100 psig |
| Surface finish: | 10µin. Ra (25µin. Ra optional) |
| Materials | |
| Body: | see ordering info |
| Valve seat: | PCTFE (VespeI® optional) |
| Diaphragm: | Hastelloy® C276 |
| Inlets and Outlets: | 1/4" / 3/8" or 1/2" face seal or tube weld |
| Bonnet port: | 1/8" NPT (on panel mount option, bonnet port is not threaded) |
| Temperature range: | -40°F to +160°F (-40°C to +71°C) |
| Leak rate: (to atmosphere) | 1x10 ⁻⁹ mbar l/s He |
| (via seat) | 1x10 ⁻⁸ mbar l/s He |
| Flow capacity: | Cv=0.13 |
| Weight: | approx. 1.54kg (depending on connections or options) |
| Supply pressure effect: | 0.25 psig rise in delivery pressure per 100 psig source pressure drop |

Flowchart

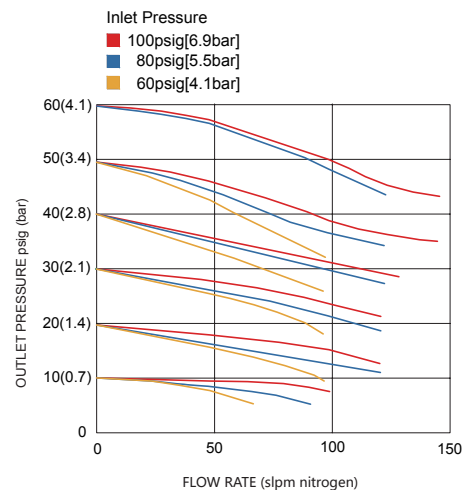
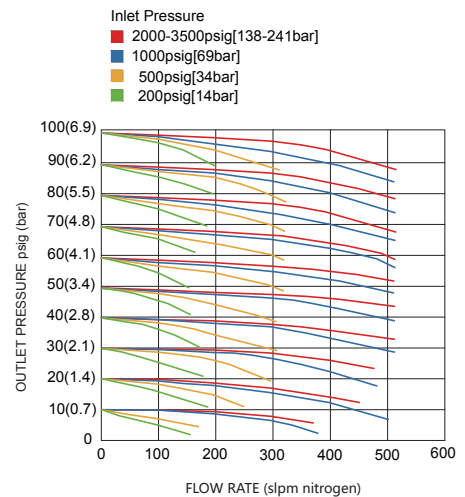

Single Stage Pressure Regulators VSR-610UB Series

Ordering Information

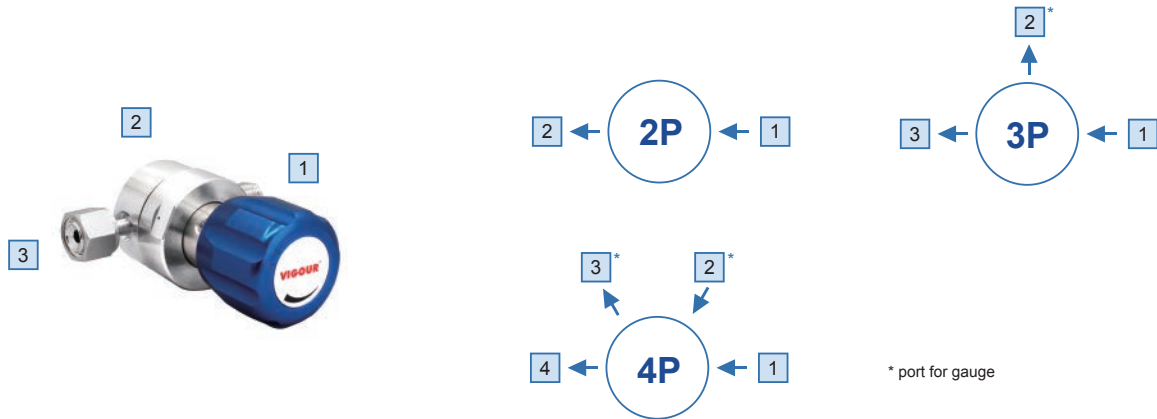

Inlet/outlet Connection

- | | |
|------------------------------|----------------------------|
| FV4: 1/4" VFS fitting female | MV8: 1/2" VFS fitting male |
| MV4: 1/4" VFS fitting male | TW4: 1/4" tube weld |
| FV6: 3/8" VFS fitting female | TW6: 3/8" tube weld |
| MV6: 3/8" VFS fitting male | TW8: 1/2" tube weld |
| FV8: 1/2" VFS fitting female | P: gauge |

* Other connection standard, consult factory

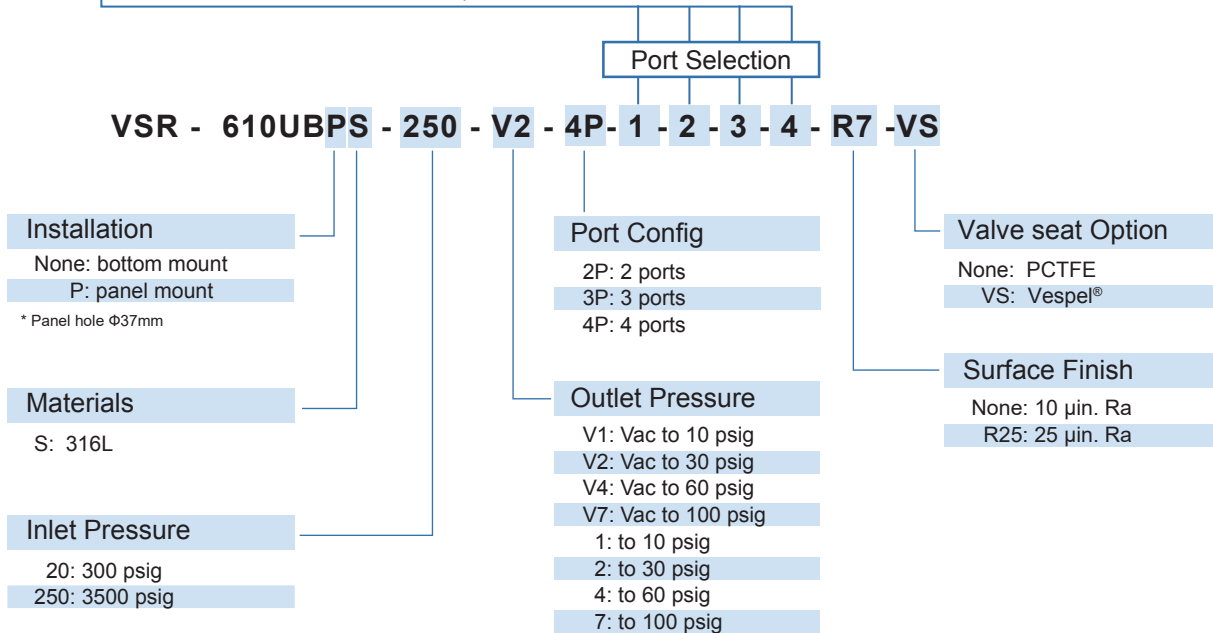

Ordering Example

VSR - 610UBS - 250 - V4 - 2P - MV4 - FV4

1 - 2



Single Stage Pressure Regulators

VSR-610UC Series

Product Feature

- Single-stage pressure regulator
- 15µin. Ra max, 10µin. Ra average surface finish (10µin. Ra max, 7µin. Ra max, 5µin. Ra max optional)
- Minimized internal volume for short purge times
- All gas-wetted parts made of stainless steel SS 316L, Hastelloy C276 and PCTFE respectively
- Internal connectors for pressure gauges
- Flow capacity: to 100 slpm
- High control accuracy
- Metal-to-metal seal to atmosphere
- Simple outlet pressure limitation by hand-wheel
- 100% helium-leak-tested



Dimensions (mm)

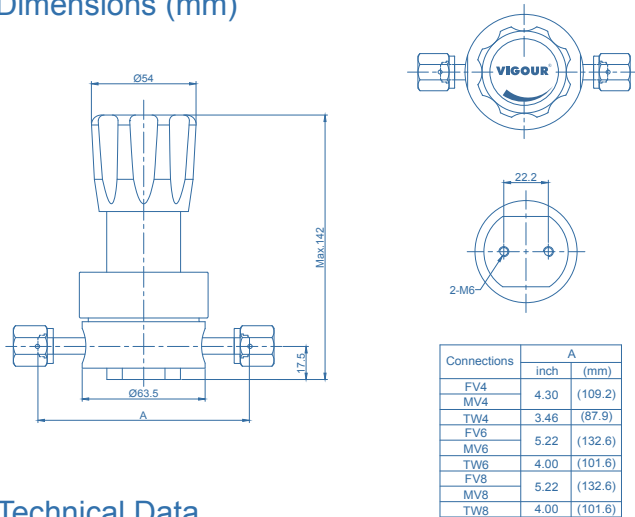

Technical Data

| | |
|----------------------------|--|
| Type: | single-stage |
| Inlet pressure P1: | max. 3500 psig |
| Outlet pressure P2: | 10/30/60/100 psig |
| Surface finish: | 15µin. Ra max / 10µin. Ra avg (10µin. Ra max., 7µin. Ra max., 5µin. Ra max optional) |
| Materials | |
| Body: | see ordering info |
| Valve seat: | PCTFE (Vespel® optional) |
| Diaphragm: | Hastelloy® C276 |
| Inlets and Outlets: | 1/4" / 3/8" or 1/2" face seal or tube weld |
| Bonnet port: | 1/8" NPT (on panel mount option, bonnet port is not threaded) |
| Temperature range: | -40°F to +160°F (-40°C to +71°C) |
| Leak rate: (to atmosphere) | 1x10 ⁻⁹ mbar l/s He |
| (via seat) | 1x10 ⁻⁹ mbar l/s He |
| Flow capacity: | Cv=0.13 |
| Weight: | approx. 1.54kg (depending on connections or options) |
| Supply pressure effect: | 0.25 psig rise in delivery pressure per 100 psig source pressure drop |

Flowchart

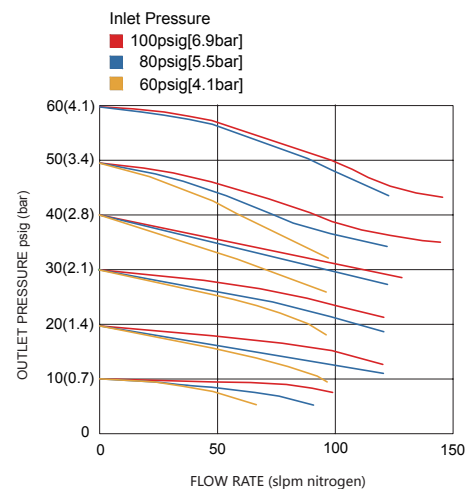
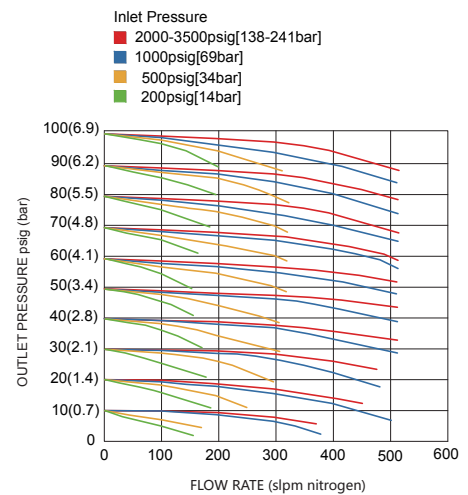

Single Stage Pressure Regulators VSR-610UC Series

Ordering Information

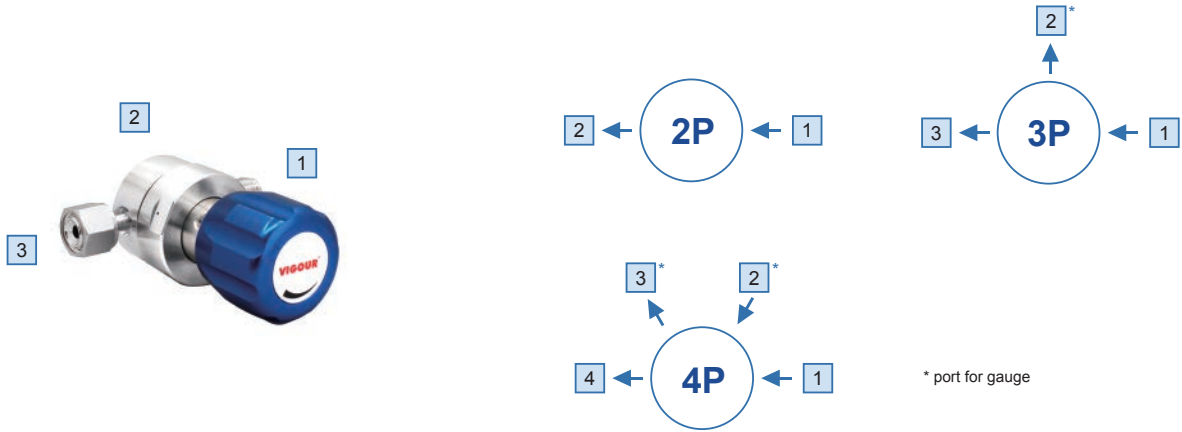

Inlet/outlet Connection

| | |
|------------------------------|----------------------------|
| FV4: 1/4" VFS fitting female | MV8: 1/2" VFS fitting male |
| MV4: 1/4" VFS fitting male | TW4: 1/4" tube weld |
| FV6: 3/8" VFS fitting female | TW6: 3/8" tube weld |
| MV6: 3/8" VFS fitting male | TW8: 1/2" tube weld |
| FV8: 1/2" VFS fitting female | P: gauge |

* Other connection standard, consult factory

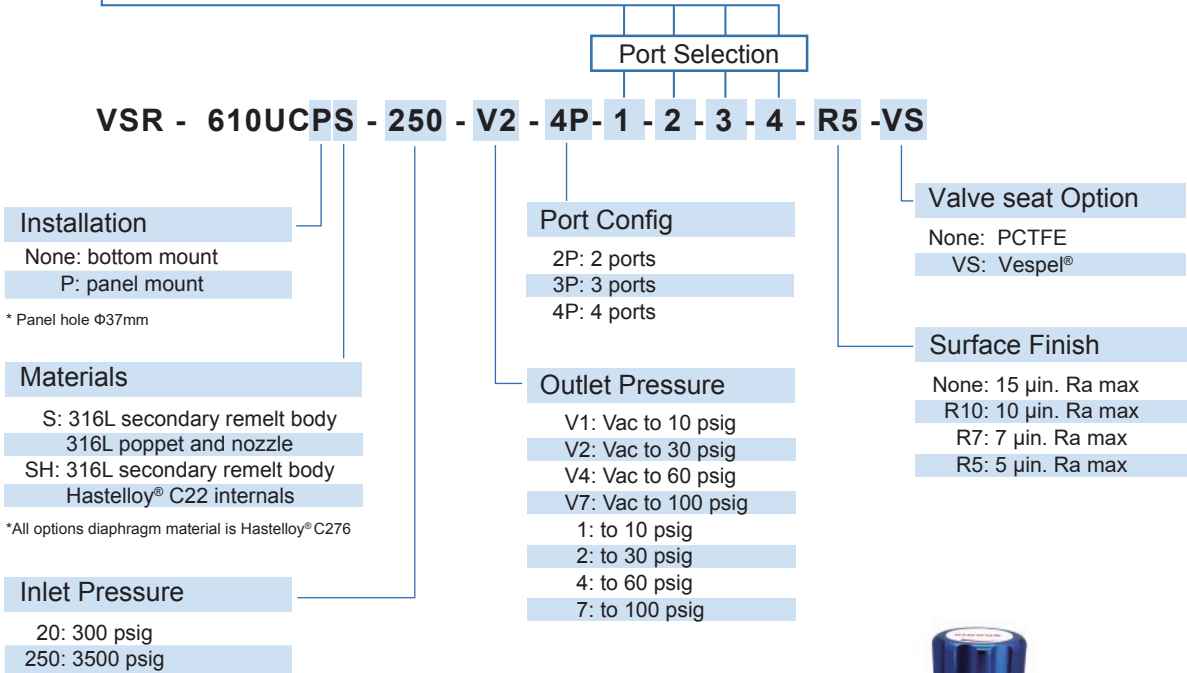

Ordering Example

VSR - 610UCS - 250 - V4 - 2P - MV4 - FV4

1 - 2



Dual Stage Pressure Regulators

VSR-710UB Series

Product Feature

- Dual-stage pressure regulator
- 10µin. Ra surface finish (25µin. Ra optional)
- Minimized internal volume for short purge times
- All gas-wetted parts made of stainless steel SS 316L, Hastelloy C276 and PCTFE respectively
- Internal connectors for pressure gauges
- Flow capacity: to 30 slpm(standard), to 120 slpm(option)
- High control accuracy
- Metal-to-metal seal to atmosphere
- Simple outlet pressure limitation by hand-wheel
- 100% helium-leak-tested
- Tied-diaphragm design



Dimensions (mm)

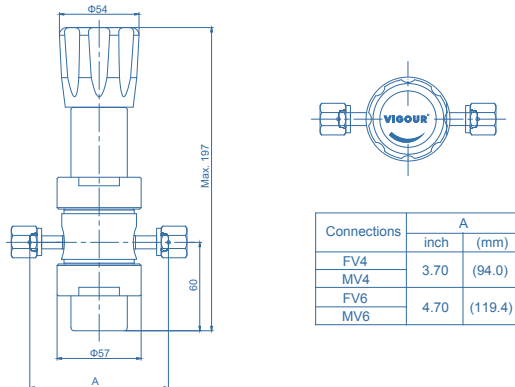

Flowchart

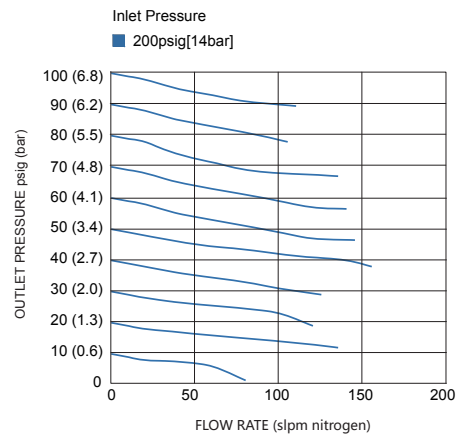

Technical Data

| | |
|----------------------------|---|
| Type: | Dual-stage |
| Inlet pressure P1: | max. 3500 psig |
| Outlet pressure P2: | 30/60/100 psig |
| Surface finish: | 10µin. Ra (25µin. Ra optional) |
| Materials | |
| Body: | see ordering info |
| Valve seat: | PCTFE (VespeI® optional) |
| Diaphragm: | Hastelloy® C276 |
| Inlets and Outlets: | 1/4" / 3/8" face seal and tube weld |
| Bonnet port: | 1/8" NPT(on panel mount option, bonnet port is not threaded) |
| Temperature range: | -40°F to +160°F (-40°C to +71°C) |
| Leak rate: (to atmosphere) | 1x10 ⁻⁹ mbar l/s He |
| (via seat) | 1x10 ⁻⁸ mbar l/s He |
| Flow capacity: | Cv=0.05 |
| Weight: | approx. 1.35kg (depending on connections or options) |
| Supply pressure effect: | 0.05 psig rise in delivery pressure per 100 psig source pressure drop |

Dual Stage Pressure Regulators VSR-710UB Series

Ordering Information

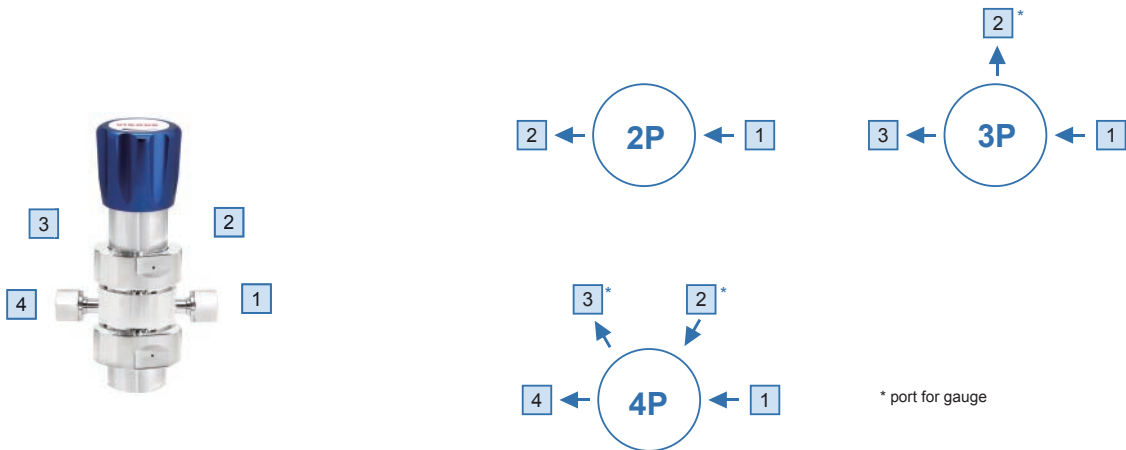

Inlet/outlet Connection

- FV4: 1/4" VFS fitting female
- MV4: 1/4" VFS fitting male
- FV6: 3/8" VFS fitting female
- MV6: 3/8" VFS fitting male
- TW4: 1/4" tube weld
- TW6: 3/8" tube weld
- P: gauge

* Other connection standard, consult factory

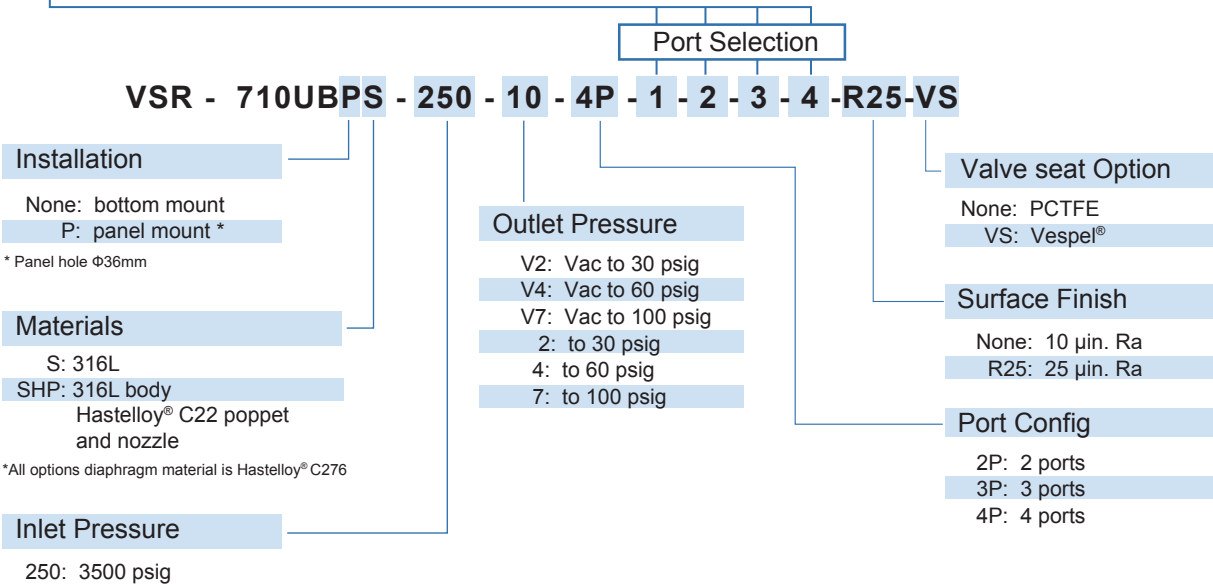

Ordering Example

VSR - 710UBS - 250 - 10 - FV4 - P - P - FV4

1 - 2 - 3 - 4



Dual Stage Pressure Regulators

VSR-710UC Series

Product Feature

- Dual-stage pressure regulator
- 15µin. Ra max, 10µin Ra average surface finish (10µin. Ra max, 7µin. Ra max. 5µin. Ra max optional)
- Minimized internal volume for short purge times
- All gas-wetted parts made of stainless steel SS 316L, Hastelloy C276 and PCTFE respectively
- Internal connectors for pressure gauges
- Flow capacity: to 30 slpm(standard), to 120 slpm(option)
- High control accuracy
- Metal-to-metal seal to atmosphere
- Simple outlet pressure limitation by hand-wheel
- 100% helium-leak-tested
- Tied-diaphragm design



Dimensions (mm)

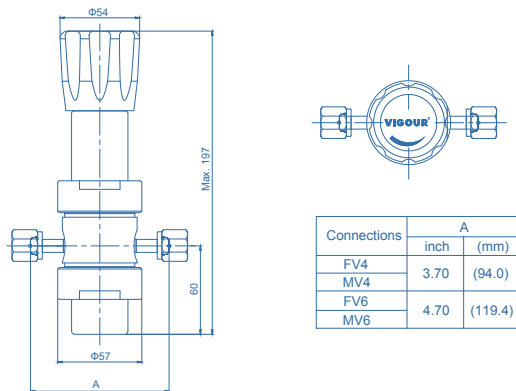

Flowchart

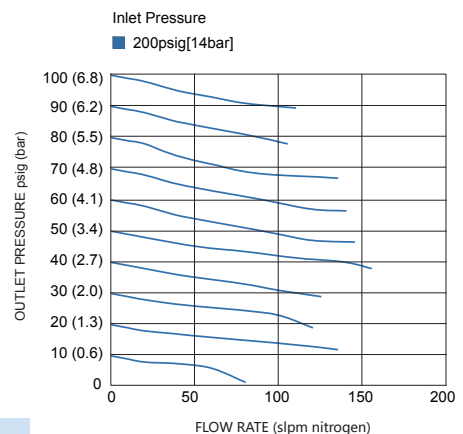

Technical Data

| | |
|----------------------------|--|
| Type: | Dual-stage |
| Inlet pressure P1: | max. 3500 psig |
| Outlet pressure P2: | 30/60/100 psig |
| Surface finish: | 15µin. Ra max, 10µin Ra average surface finish (10µin. Ra max, 7µin. Ra max. 5µin. Ra max optional) |
| Materials | |
| Body: | see ordering info |
| Valve seat: | PCTFE (VespeI® optional) |
| Diaphragm: | Hastelloy® C276 |
| Inlets and Outlets: | 1/4" / 3/8" face seal and tube weld |
| Bonnet port: | 1/8" NPT(on panel mount option, bonnet port is not threaded) |
| Temperature range: | -40°F to +160°F (-40°C to +71°C) |
| Leak rate: (to atmosphere) | 1x10 ⁻⁹ mbar I/s He |
| (via seat) | 1x10 ⁻⁸ mbar I/s He |
| Flow capacity: | Cv=0.05 |
| Weight: | approx. 1.35kg (depending on connections or options) |
| Supply pressure effect: | 0.05 psig rise in delivery pressure per 100 psig source pressure drop |

Dual Stage Pressure Regulators VSR-710UC Series

Ordering Information

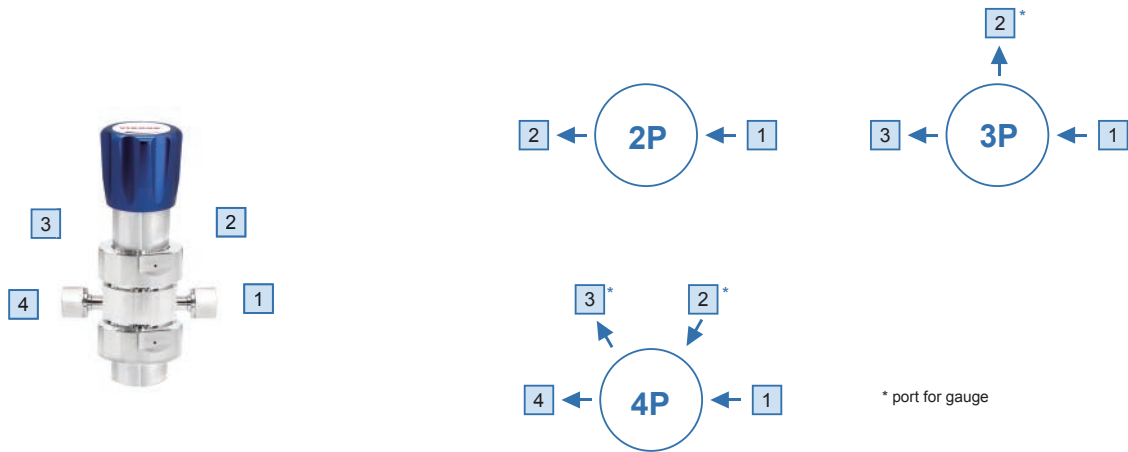

Inlet/outlet Connection

FV4: 1/4" VFS fitting female
MV4: 1/4" VFS fitting male
FV6: 3/8" VFS fitting female
MV6: 3/8" VFS fitting male

TW4: 1/4" tube weld
TW6: 3/8" tube weld
P: gauge

* Other connection standard, consult factory

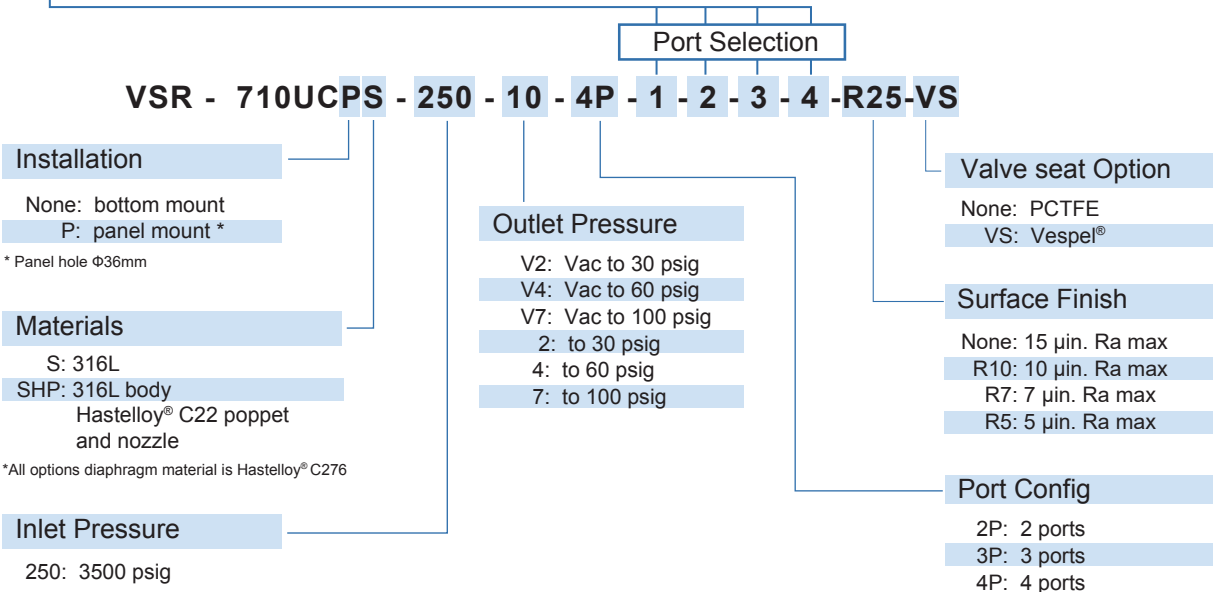

Ordering Example

VSR - 710UCS - 250 - 10 - FV4 - P - P - FV4

1 - 2 - 3 - 4



Single Stage Pressure Regulators

VSR-910UB Series

Product Feature

- Single-stage pressure regulator
- 15µin. Ra max. 10µin Ra max optional
- design for bulk special gas supply system
- Tied diaphragm design with bellows sensory element
- All gas-wetted parts made of stainless steel SS 316L, Hastelloy C276 and PCTFE respectively
- Metal-to-metal seal to atmosphere
- 100% helium-leak-tested

Dimensions (mm)

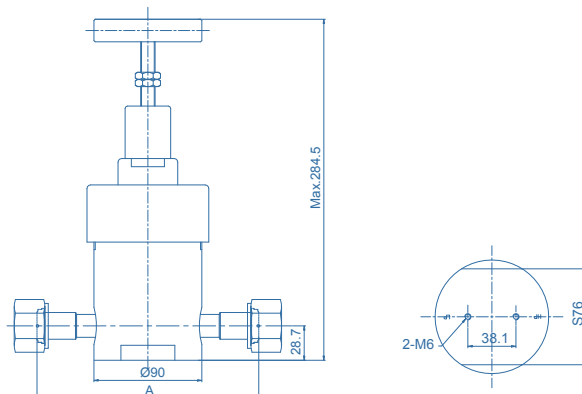

| Connections | A | |
|-------------|------|---------|
| | inch | (mm) |
| FV8 | 6.22 | (158.0) |
| MV8 | 6.22 | (158.0) |
| TW8 | 9.50 | (241.4) |
| FV12 | 7.28 | (185.0) |
| MV12 | 7.28 | (185.0) |
| TW12 | 9.50 | (241.4) |
| FV16 | 7.84 | (199.2) |
| MV16 | 7.84 | (199.2) |
| TW16 | 9.50 | (241.4) |

Technical Data

| | |
|----------------------------|---|
| Type: | single-stage |
| Inlet pressure P1: | max. 3000 psig |
| Outlet pressure P2: | 30/60/100/150 psig |
| Surface finish: | 15µin. Ra max 10µin. Ra max (optional) |
| Materials | |
| Body: | SS 316L |
| Valve seat: | PCTFE (Vespel® optional) |
| Diaphragm: | Hastelloy® C22 |
| Inlets and Outlets: | 1/2" / 3/4" or 1" face seal or tube weld |
| Bonnet port: | 1/8" FNPT(option) |
| Temperature range: | -40°F to +160°F (-40°C to +71°C) |
| Leak rate: (to atmosphere) | 1x10 ⁻⁹ mbar l/s He |
| (via seat) | 1x10 ⁻⁸ mbar l/s He |
| Flow capacity: | Cv=4 |
| Weight: | 6.7kg |

Flowchart

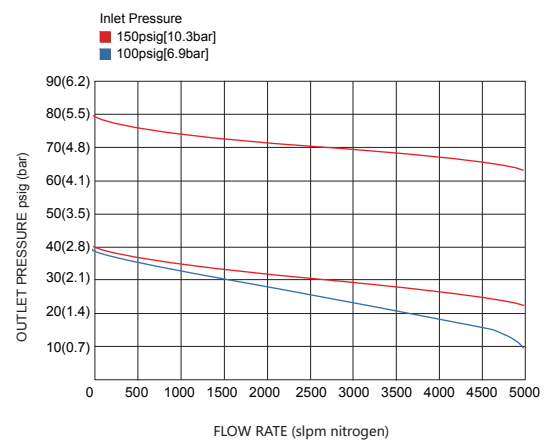

Single Stage Pressure Regulators VSR-910UB Series

Ordering Information

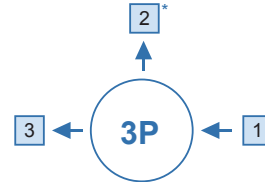

* port for gauge

Inlet/Outlet Connection

FV8: 1/2" VFS fitting female
MV8: 1/2" VFS fitting male
FV12: 3/4" VFS fitting female
MV12: 3/4" VFS fitting male

FV16: 1" VFS fitting female
MV16: 1" VFS fitting male
MV4: 1/4" VFS fitting male
(for gauge port)

TW8: 1/2" tube weld
TW12: 3/4" tube weld
TW16: 1" tube weld
P: gauge

* Other connection standard, consult factory

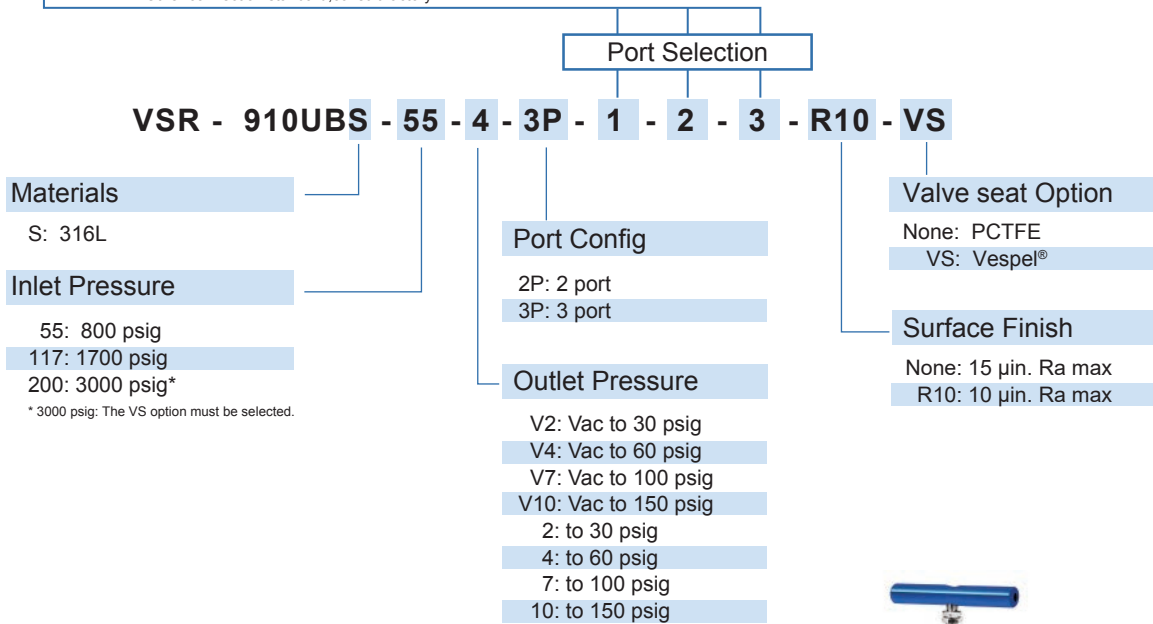

Ordering Example

VSR - 910UBS - 55 - 10 - 2P - MV12 - FV12

1 - 2



Single Stage Pressure Regulators

VSR-911UB Series

Product Feature

- Single-stage pressure regulator
- 15µin. Ra max. 10µin Ra max optional
- design for bulk special gas supply system
- Tied diaphragm design with bellows sensory element
- All gas-wetted parts made of stainless steel SS 316L, Hastelloy C276 and PCTFE respectively
- Metal-to-metal seal to atmosphere
- 100% helium-leak-tested

Dimensions (mm)

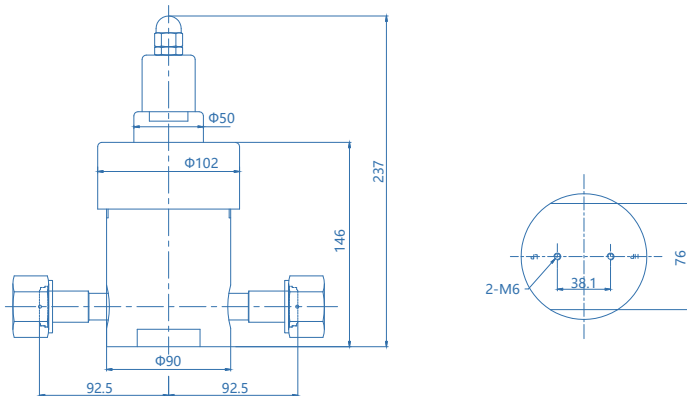

| Connections | A | |
|-------------|------|---------|
| | inch | (mm) |
| FV8 | 6.22 | (158.0) |
| MV8 | 6.22 | (158.0) |
| TW8 | 9.50 | (241.4) |
| FV12 | 7.28 | (185.0) |
| MV12 | 7.28 | (185.0) |
| TW12 | 9.50 | (241.4) |
| FV16 | 7.84 | (199.2) |
| MV16 | 7.84 | (199.2) |
| TW16 | 9.50 | (241.4) |

Technical Data

| | |
|----------------------------|---|
| Type: | single-stage |
| Inlet pressure P1: | max. 3000 psig |
| Outlet pressure P2: | 300 psig |
| Surface finish: | 15µin. Ra max 10µin. Ra max (optional) |
| Materials | |
| Body: | SS 316L |
| Valve seat: | PCTFE (Vespe ^l ® optional) |
| Diaphragm: | Hastelloy [®] C22 |
| Inlets and Outlets: | 1/2" / 3/4" or 1" face seal or tube weld |
| Bonnet port: | 1/8" FNPT(option) |
| Temperature range: | -40°F to +160°F (-40°C to +71°C) |
| Leak rate: (to atmosphere) | 1x10 ⁻⁹ mbar l/s He |
| (via seat) | 1x10 ⁻⁹ mbar l/s He |
| Flow capacity: | Cv=3 |
| Weight: | 6.7kg |

Flowchart

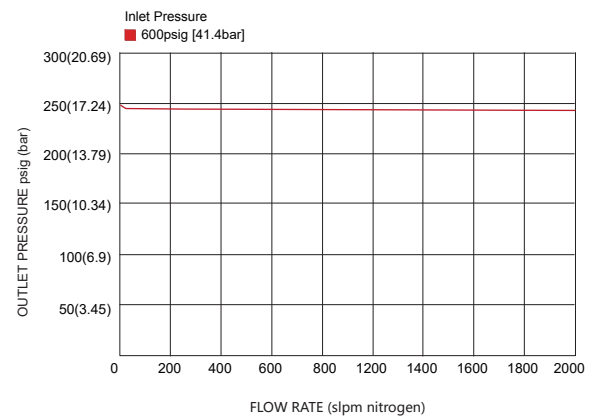

Single Stage Pressure Regulators VSR-911UB Series

Ordering Information

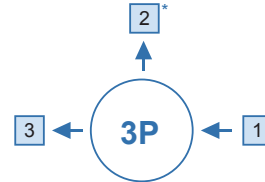

* port for gauge

Inlet/Outlet Connection

FV8: 1/2" VFS female

MV8: 1/2" VFS male

FV12: 3/4" VFS female

MV12: 3/4" VFS male

FV16: 1" VFS female

MV16: 1" VFS male

MV4: 1/4" VFS male

(for gauge port)

TW8: 1/2" tube weld

TW12: 3/4" tube weld

TW16: 1" tube weld

P: gauge

* Other connection standard, consult factory

Port Selection

VSR - 911UBS - 55 - P21 - 3P - 1 - 2 - 3 - R10 - VS

Materials

S: 316L

Inlet Pressure

55: 800 psig

117: 1700 psig

200: 3000 psig*

* 3000 psig: The VS option must be selected.

Port Config

2P: 2 port

3P: 3 port

Outlet Pressure

P21: Preset to 300 psig*

* 300 psig outlet pressure preset at 800 psig (55 bar) inlet pressure.

Valve seat Option

None: PCTFE

VS: Vespel®

Surface Finish

None: 15 µin. Ra max

R10: 10 µin. Ra max

Ordering Example

VSR - 911UBS - 55 - P21 - 2P - MV12 - FV12

1 - 2



Single Stage Pressure Regulators

VSR-920UB Series

Product Feature

- Single-stage pressure regulator
- 10µin. Ra surface finish
- Minimized internal volume for short purge times
- All gas-wetted parts made of stainless steel SS 316L, Hastelloy C276 and PCTFE respectively
- Internal connectors for pressure gauges
- Flow capacity: to 2000 slpm
- High control accuracy
- Metal-to-metal seal to atmosphere
- Simple outlet pressure limitation by hand-wheel
- 100% helium-leak-tested
- Tied-diaphragm design



Dimensions (mm)

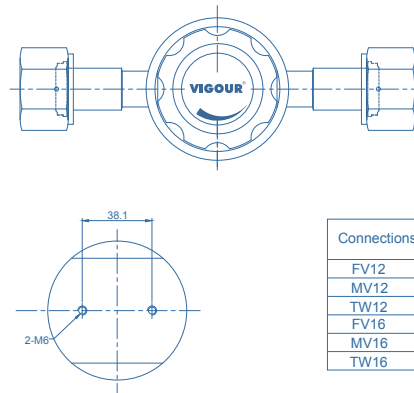
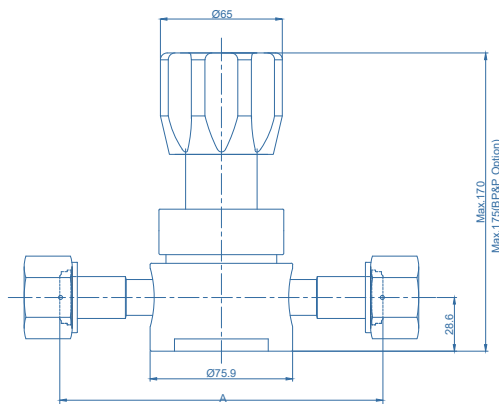

| Connections | A | |
|-------------|------|---------|
| | inch | (mm) |
| FV12 | 6.78 | (172.2) |
| MV12 | 6.00 | (152.4) |
| TW12 | 6.00 | (152.4) |
| FV16 | 7.34 | (186.4) |
| MV16 | 6.00 | (152.4) |
| TW16 | 6.00 | (152.4) |

Technical Data

| | |
|----------------------------|--|
| Type: | single-stage |
| Inlet pressure P1: | max. 300 psig |
| Outlet pressure P2: | 30/60/100/150 psig |
| Surface finish: | 10µin. Ra |
| Materials | |
| Body: | see ordering info |
| Valve seat: | PFA (Vespe ^l ® optional) |
| Diaphragm: | Hastelloy® C276 |
| Inlets and Outlets: | 3/4" / 1" VFS fitting or tube weld |
| Bonnet port: | 1/8" FNPT(option) |
| Temperature range: | -40°F to +160°F (-40°C to +71°C) |
| Leak rate: (to atmosphere) | 1x10 ⁻⁹ mbar l/s He |
| (via seat) | 1x10 ⁻⁸ mbar l/s He |
| Flow capacity: | Cv=1.6 |
| Weight: | approx. 2.72kg (depending on connections or options) |
| Supply pressure effect: | 7 psig rise in delivery pressure per 100 psig source pressure drop |

Flowchart

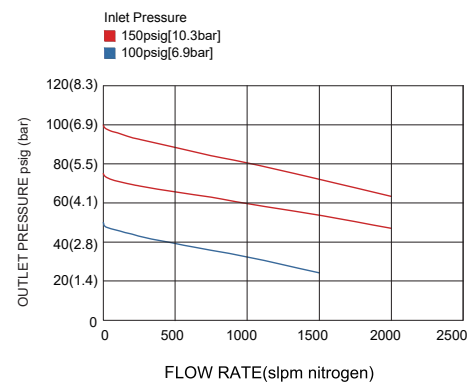

Single Stage Pressure Regulators VSR-920UB Series

Ordering Information

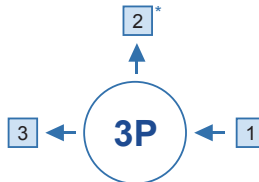

* port for gauge

Inlet/Outlet Connection

| | | |
|-----------------------|----------------------|----------------------|
| FV12: 3/4" VFS female | FV4: 1/4" VFS female | TW12: 3/4" tube weld |
| MV12: 3/4" VFS male | (for gauge port) | TW16: 1" tube weld |
| FV16: 1" VFS female | MV4: 1/4" VFS male | P: gauge |
| MV16: 1" VFS male | (for gauge port) | |

* Other connection standard, consult factory

Port Selection

VSR - 920UBPS - 20 - V4 - 3P - 1 - 2 - 3 - VS

Installation

None: bottom mount
P: panel mount*
BP: bonnet port (1/8" FNPT)

* Panel hole Φ 39.6mm

Materials

S: 316L

Inlet Pressure

20: 300 psig

Outlet Pressure

V2: Vac to 30 psig
V4: Vac to 60 psig
V7: Vac to 100 psig
V10: Vac to 150 psig
2: to 30 psig
4: to 60 psig
7: to 100 psig
10: to 150 psig

Valve Seat Option

None: PFA (standard)
VS: Vespel®

Port Config

2P: 2 ports
3P: 3 ports

Ordering Example

VSR - 920UBS - 20 - 10 - 2P - MV12 - FV12

1 - 2



Single Stage Pressure Regulators

VSR-920UC Series

Product Feature

- Single-stage pressure regulator
- 10µin. Ra surface finish
- Minimized internal volume for short purge times
- All gas-wetted parts made of stainless steel SS 316L, Hastelloy C276 and PCTFE respectively
- Internal connectors for pressure gauges
- Flow capacity: to 2000 slpm
- High control accuracy
- Metal-to-metal seal to atmosphere
- Simple outlet pressure limitation by hand-wheel
- 100% helium-leak-tested
- Tied-diaphragm design



Dimensions (mm)

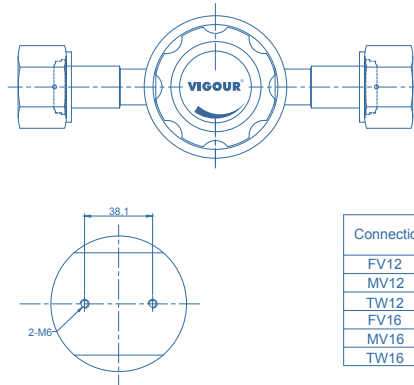
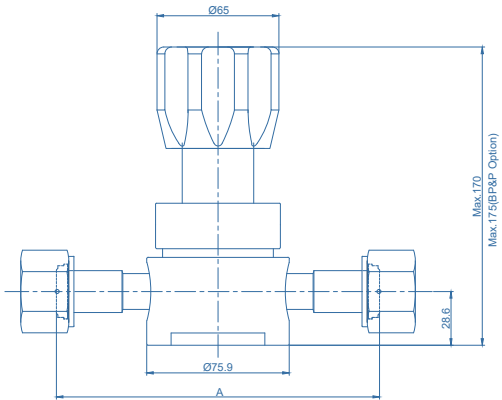

| Connections | A | |
|-------------|------|---------|
| | inch | (mm) |
| FV12 | 6.78 | (172.2) |
| MV12 | 6.00 | (152.4) |
| TW12 | 6.00 | (152.4) |
| FV16 | 7.34 | (186.4) |
| MV16 | 6.00 | (152.4) |
| TW16 | 6.00 | (152.4) |

Technical Data

| | |
|----------------------------|---|
| Type: | single-stage |
| Inlet pressure P1: | max. 300 psig |
| Outlet pressure P2: | 30/60/100/150 psig |
| Surface finish: | 15µin. Ra max / 10µin. Ra avg (10µin. Ra max optional) |
| Materials | |
| Body: | see ordering info |
| Valve seat: | PFA (VespeI® optional) |
| Diaphragm: | Hastelloy® C276 |
| Inlets and Outlets: | 3/4" / 1" VFS fitting or tube weld |
| Bonnet port: | 1/8" FNPT(option) |
| Temperature range: | -40°F to +160°F (-40°C to +71°C) |
| Leak rate: (to atmosphere) | 1x10 ⁻⁹ mbar l/s He |
| (via seat) | 1x10 ⁻⁸ mbar l/s He |
| Flow capacity: | Cv=1.6 |
| Weight: | approx. 2.72kg (depending on connections or options) |
| Supply pressure effect: | 7 psig rise in delivery pressure per 100 psig source pressure drop |

Flowchart

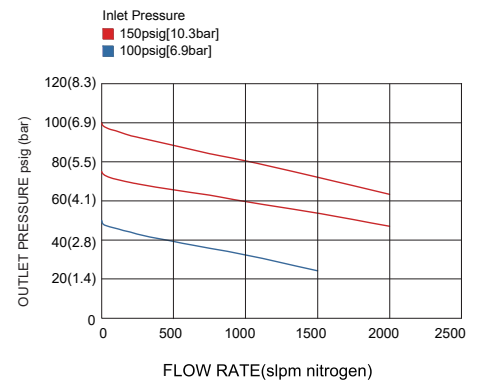

Single Stage Pressure Regulators VSR-920UC Series

Ordering Information

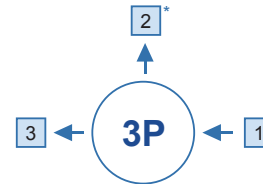

* port for gauge

Inlet/Outlet Connection

| | | |
|-----------------------|----------------------|----------------------|
| FV12: 3/4" VFS female | FV4: 1/4" VFS female | TW12: 3/4" tube weld |
| MV12: 3/4" VFS male | (for gauge port) | TW16: 1" tube weld |
| FV16: 1" VFS female | MV4: 1/4" VFS male | P: gauge |
| MV16: 1" VFS male | (for gauge port) | |

* Other connection standard, consult factory

Port Selection

VSR - 920UCPS - 20 - V4 - 3P - 1 - 2 - 3 - VS

Installation

None: bottom mount
P: panel mount*
BP: bonnet port (1/8" FNPT)
* Panel hole Φ39.6mm

Materials

S: 316L

Inlet Pressure

20: 300 psig

Outlet Pressure

V2: Vac to 30 psig
V4: Vac to 60 psig
V7: Vac to 100 psig
V10: Vac to 150 psig
2: to 30 psig
4: to 60 psig
7: to 100 psig
10: to 150 psig

Valve Seat Option

None: PFA (standard)
VS: Vespel®

Port Config

2P: 2 ports
3P: 3 ports

Ordering Example

VSR - 920UCS - 20 - 10 - 2P - MV12 - FV12
1 - 2



Diaphragm Valves

VDV31UA Series

Product Feature

- Diaphragm valve
- Stainless steel 316L body for corrosive gases
- Inlet pressure max 300 bar
- Left or Right lever direction for Shutoff
- Wide range of inlets and outlets
- Metal-to-metal seal to atmosphere



Temperature / Pressure Rating

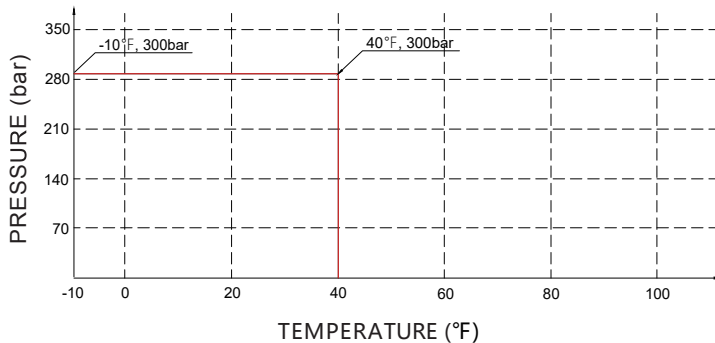

Schematic Drawing

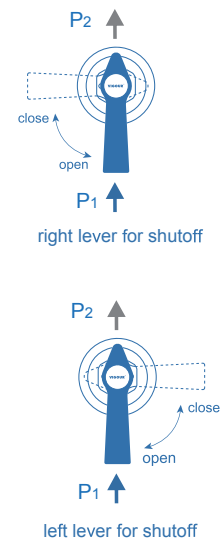

Technical Data

| | |
|-----------------------------|--------------------------------|
| Max. Working Pressure: | 4500 psig (300 bar) |
| Max. Working Temp.: | -10°F ~ 150°F (-23°C ~ 65°C) |
| Materials | |
| Body: | 316L |
| Diaphragm: | Elgiloy® |
| Seat packing: | PEEK |
| Handle: | AL |
| Internal Leakage Allowance: | 1x10 ⁻⁹ mbar l/s He |
| External Leakage Allowance: | 1x10 ⁻⁹ mbar l/s He |
| Flow capacity: | Cv=0.1 |
| Orifice: | Φ2.7mm |
| Weight: | approx. 0.25kg |

Dimensions (mm)

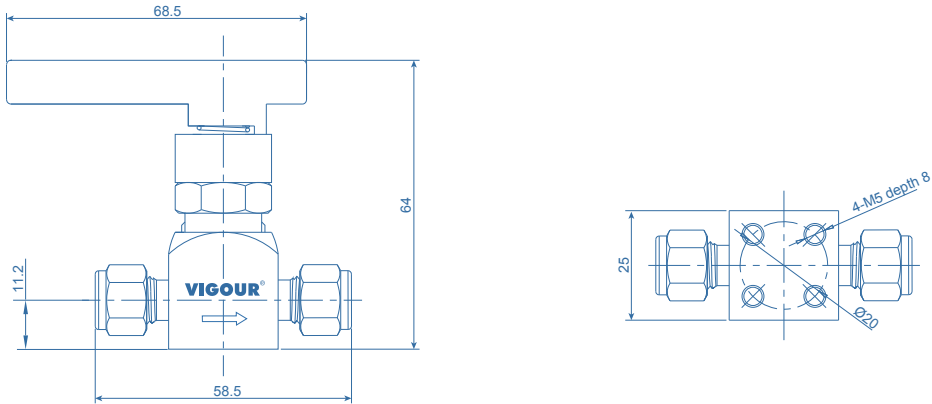

Ordering Information

VDV31UAS - 04 - 04 - L

Materials

S: 316L

Inlets / Outlets

M4: 1/4" NPT(M)

02: 1/8" tube fitting

04: 1/4" tube fitting

6M: 6mm tube fitting

8M: 8mm tube fitting

Lever

None: right lever for shutoff

L: left lever for shutoff

Diaphragm Valves

VDV32UA Series

Product Feature

- Suitable for high purity, flammable or toxic fluid gases
- Direct diaphragm construction with superior sealing performance, remarkable durability, compactness and particle and dead-space-free performance
- Valve open and closed option is easily visible at a glance
- Excellent gas displacement characteristics
- Standard seat material is PCTFE, Ployimede/PFA is option

Temperature / Pressure Rating

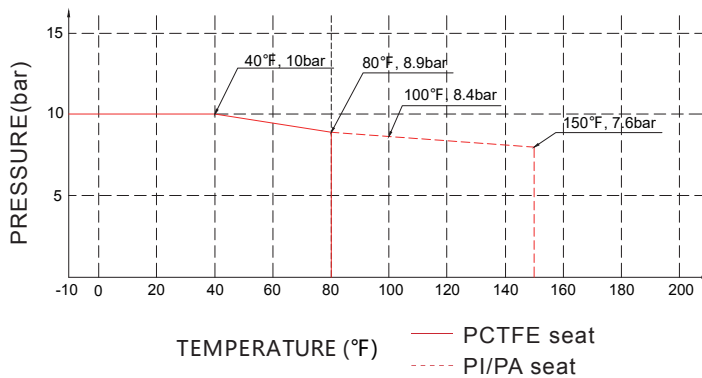

1/4 Type



1/4 Type



1/2 Type



1/2 Type

Technical Data

| | |
|-------------------------------|--|
| Max. Working Pressure: | 150 psig (10 bar) |
| Pneumatic Operating Pressure: | 58~87psig (4-6bar) |
| Max. Working Temp.: | -10°F ~ 150°F (-23°C ~ 65°C) |
| Materials | |
| Body: | 316L |
| Diaphragm: | Elgiloy® |
| Seat packing: | PCTFE |
| Handle: | AL |
| Internal Leakage Allowance: | 1x10 ⁻⁹ mbar l/s He |
| External Leakage Allowance: | 1x10 ⁻⁹ mbar l/s He |
| Flow capacity: | Cv=0.3 (Cv=0.65 option) |
| Weight: | approx. 0.27kg (actuator not included) |

Dimensions (mm)

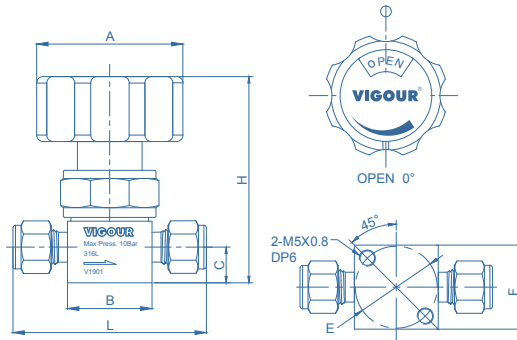

1/4, 3/8, 1/2 manual actuator

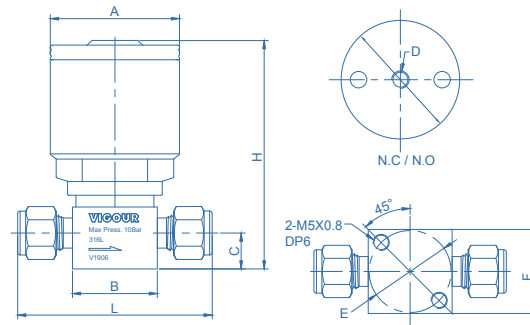

1/4 pneumatic actuator

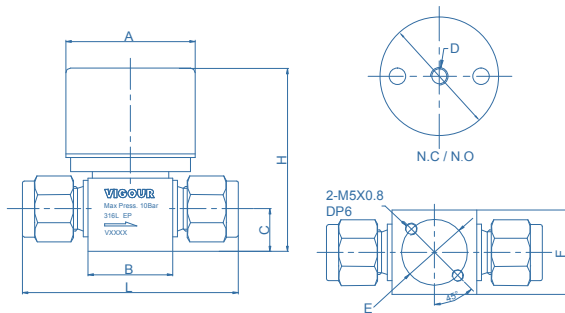

3/8, 1/2 pneumatic actuator

manual actuator

| End Conections | Orifice (mm) | Dimensions (mm) | | | | | | | |
|-------------------|--------------|-----------------|----|------|-------|----|------|----|--|
| | | A | B | C | E | F | L | H | |
| 1/4" Tube Fitting | 4.4 | Φ45 | 26 | 11 | Φ25.4 | 26 | 60 | 64 | |
| 3/8" Tube Fitting | 7 | Φ45 | 36 | 18.2 | Φ28 | 36 | 78.8 | 78 | |
| 1/2" Tube Fitting | 7 | Φ45 | 36 | 18.2 | Φ28 | 36 | 83.6 | 78 | |

pneumatic actuator, normally opened / normally closed

| End Conections | Actuator | Orifice (mm) | Dimensions (mm) | | | | | | | |
|-------------------|-----------|--------------|-----------------|----|------|--------|-------|----|------|----|
| | | | A | B | C | D | E | F | L | H |
| 1/4" Tube Fitting | N.C / N.O | 4.4 | Φ39.6 | 26 | 11 | M5x0.8 | Φ25.4 | 26 | 60 | 70 |
| 3/8" Tube Fitting | N.C / N.O | 7 | Φ55 | 36 | 18.2 | RC 1/8 | Φ28 | 36 | 78.8 | 78 |
| 1/2" Tube Fitting | N.C / N.O | 7 | Φ55 | 36 | 18.2 | RC 1/8 | Φ28 | 36 | 83.6 | 78 |

1/4", 3/8", 1/2" tube fitting dimensions for reference, other connections please contact factory.

Ordering information

VDV32UAS - M - 04 - 04 - PA

Materials

S: 316L

Actuator

M: manual actuator
PO: pneumatic actuator, normally opened
PC: pneumatic actuator, normally closed

Valve Seat Option

None: PCTFE (standard)
VS: Vespel®
PA: PFA

End Connection

04: 1/4" tube fitting
06: 3/8" tube fitting
08: 1/2" tube fitting

* Other connection standard, consult factory

Diaphragm Valves

VDV33UA Series

Product Feature

- Suitable for high purity, flammable or toxic gases
- Direct diaphragm construction with superior sealing performance, remarkable durability, compactness and particle and dead-space-free performance
- Valve open and closed option is easily visible at a glance
- Excellent gas displacement characteristics
- Standard seat material is PEEK, Ployimede/PFA is option

Temperature / Pressure Rating

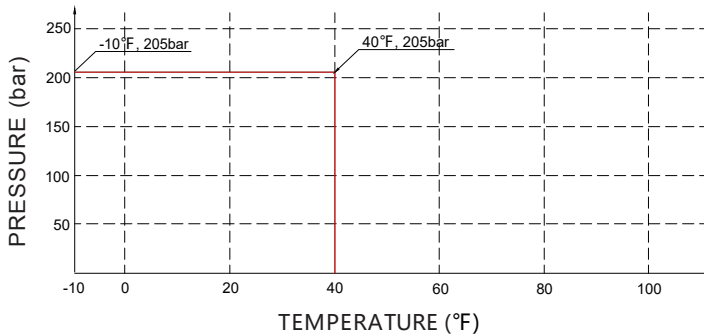

1/4 Type



1/4 Type



1/2 Type



1/2 Type

Technical Data

| | |
|-------------------------------|--|
| Max. Working Pressure: | 3000 psig (206 bar) |
| Pneumatic Operating Pressure: | 58~87psig (4-6bar) |
| Max. Working Temp.: | -10°F ~ 150°F (-23°C ~ 65°C) |
| Materials | |
| Body: | 316L |
| Diaphragm: | Elgiloy® |
| Seat packing: | PEEK |
| Handle: | AL |
| Internal Leakage Allowance: | 1x10 ⁻⁹ mbar l/s He |
| External Leakage Allowance: | 1x10 ⁻⁹ mbar l/s He |
| Flow capacity: | Cv=0.1 (Cv=0.5 option) |
| Weight: | approx. 0.27kg (actuator not included) |

Dimensions (mm)

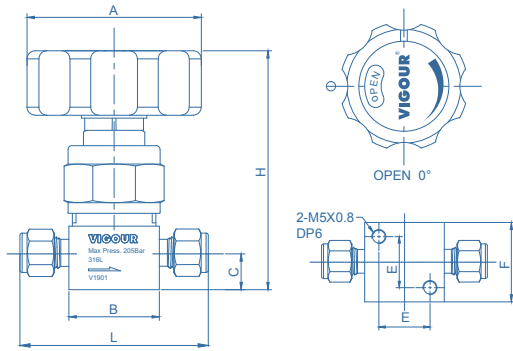

1/4, 3/8, 1/2 manual actuator

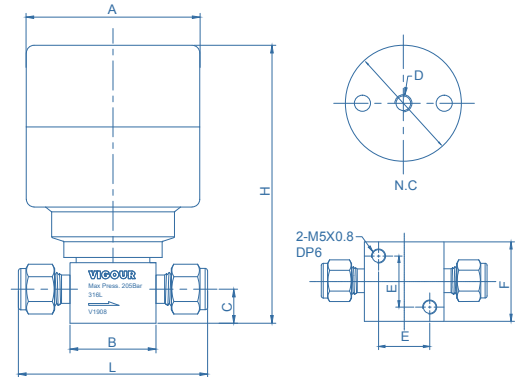

1/4, 3/8, 1/2 pneumatic actuator (N.C)

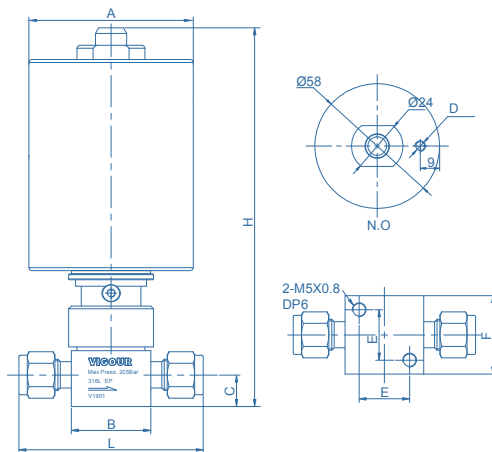

1/4 pneumatic actuator (N.O)

manual actuator

| End Conections | Orifice (mm) | Dimensions (mm) | | | | | | |
|-------------------|--------------|-----------------|----|------|----|----|------|----|
| | | A | B | C | E | F | L | H |
| 1/4" Tube Fitting | 4.4 | Φ54 | 28 | 11.1 | 18 | 28 | 65 | 74 |
| 3/8" Tube Fitting | 7 | Φ54 | 42 | 18.2 | 27 | 38 | 84.8 | 86 |
| 1/2" Tube Fitting | 7 | Φ54 | 42 | 18.2 | 27 | 38 | 89.6 | 86 |

pneumatic actuator, normally opened / normally closed

| End Conections | Actuator | Orifice (mm) | Dimensions (mm) | | | | | | | |
|-------------------|----------|--------------|-----------------|----|------|--------|----|----|------|------|
| | | | A | B | C | D | E | F | L | H |
| 1/4" Tube Fitting | N.C | 4.4 | Φ56.5 | 28 | 11.1 | M5x0.8 | 18 | 28 | 65 | 90.5 |
| 1/4" Tube Fitting | N.O | 4.4 | Φ58 | 28 | 11.1 | M5x0.8 | 18 | 28 | 65 | 134 |
| 3/8" Tube Fitting | N.C | 7 | Φ56.5 | 42 | 18.2 | RC 1/8 | 27 | 38 | 84.8 | 105 |
| 1/2" Tube Fitting | N.C | 7 | Φ56.5 | 42 | 18.2 | M5x0.8 | 27 | 38 | 89.6 | 105 |

1/4", 3/8", 1/2" tube fitting dimensions for reference, other connections please contact factory.

Ordering Information

VDV33UAS - M - 04 - 04 - PA

Materials

S: 316L

Actuator

M: manual actuator

PO: pneumatic actuator, normally opened *

PC: pneumatic actuator, normally closed

*Normally opened available with connetion size 1/4 thch.

Valve Seat Option

None: PEEK (standard)

PA: PFA

VS: Vespel®

End Connection

F4: 1/4" NPT(F)

04: 1/4" tube fitting

06: 3/8" tube fitting

08: 1/2" tube fitting

* Other connection standard, consult factory

Diaphragm Valves

VDV31UB Series

Product Feature

- Quarter-turn ON/OFF, providing easy operation
- Handle shape provides visual indication of OPEN and CLOSE position
- Available on high and low-pressure models



Temperature / Pressure Rating

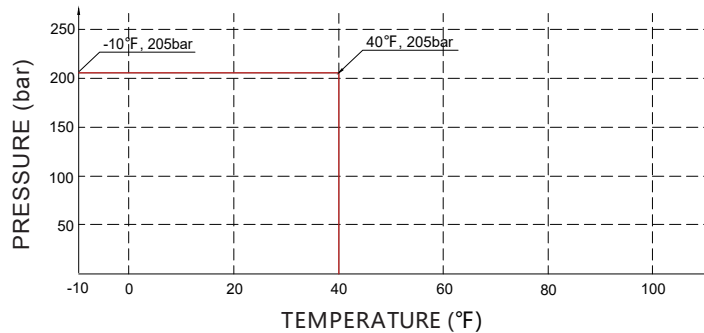

Technical Data

| | |
|-----------------------------|--------------------------------|
| Max. Working Pressure: | 3000 psig (206 bar) |
| Max. Working Temp.: | -10°F ~ 150°F (-23°C ~ 65°C) |
| Materials | |
| Body: | 316L secondary remelt |
| Diaphragm: | Elgiloy® |
| Seat packing: | PEEK |
| Handle: | AL |
| Internal Leakage Allowance: | 1x10 ⁻⁹ mbar l/s He |
| External Leakage Allowance: | 1x10 ⁻⁹ mbar l/s He |
| Flow capacity: | Cv=0.1 |
| Orifice: | Φ4.0mm |
| Weight: | approx. 0.25kg |

Dimensions (mm)

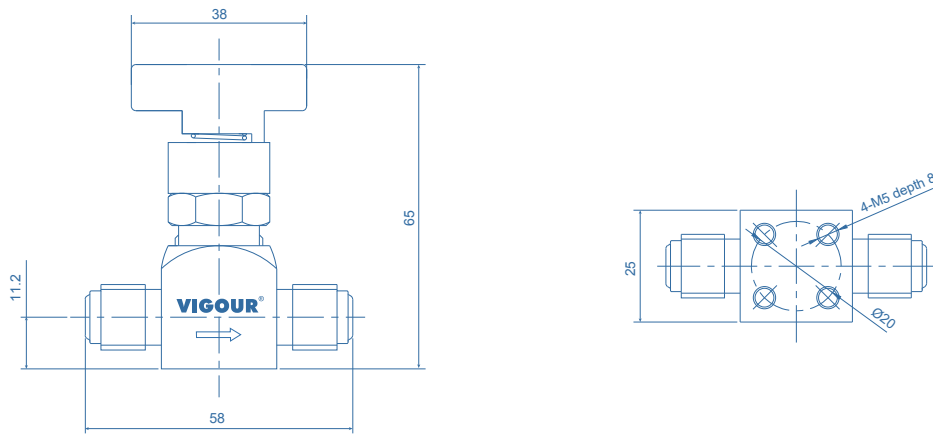

Ordering Information

VDV31UBS - MV4 - MV4

Materials

S: 316L
SLV: 316L secondary remelt

End Connection

MV4: 1/4" VFS male

* Other connection standard, consult factory

Diaphragm Valves

VDV32UB Series

Product Feature

- Suitable for ultra pure, flammable or toxic fluid lines in semiconductor manufacturing equipment and facilities
- Direct diaphragm construction with superior sealing performance, remarkable durability, compactness and particle and dead-space-free performance
- Valve open and closed position is easily visible at a glance
- Excellent gas displacement characteristics
- EP treatment is standard for all wetted surfaces
- Standard seat material is PCTFE, Polyimide/PFA is option

Temperature / Pressure Rating

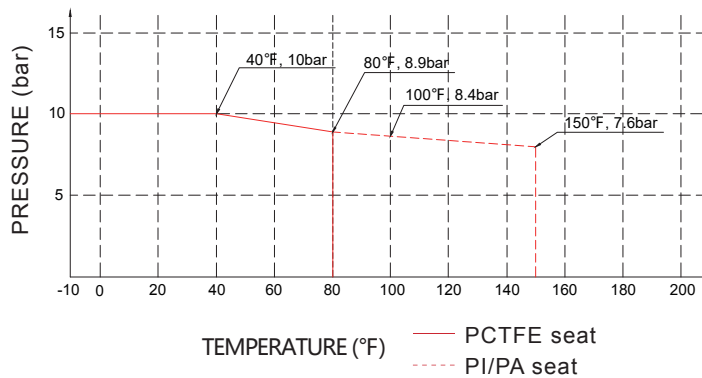

Technical Data

| | |
|-------------------------------|--|
| Max. Working Pressure: | 150 psig (10 bar) |
| Pneumatic Operating Pressure: | 58~87psig (4-6bar) |
| Max. Working Temp.: | -10°F ~ 150°F (-23°C ~ 65°C) |
| Surface finish: | 10µin. Ra |
| Materials | |
| Body: | see ordering info |
| Diaphragm: | Elgiloy® |
| Seat packing: | PCTFE |
| Handle: | AL |
| Internal Leakage Allowance: | 1x10 ⁻⁹ mbar l/s He |
| External Leakage Allowance: | 1x10 ⁻⁹ mbar l/s He |
| Flow capacity: | 1/4" Cv=0.3 3/8" Cv=0.65 |
| Weight: | approx. 0.27kg (actuator not included) |



1/4 Type



1/4 Type



1/2 Type



1/2 Type

Diaphragm Valves VDV32UB Series

Dimensions (mm)

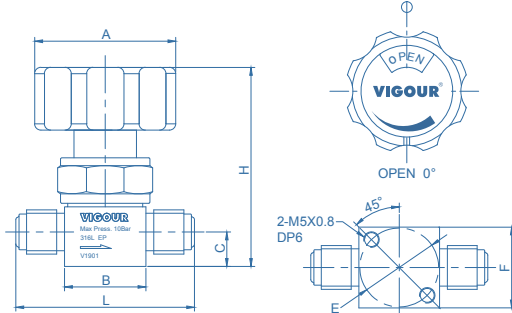

1/4, 3/8, 1/2 manual actuator (VFS male)

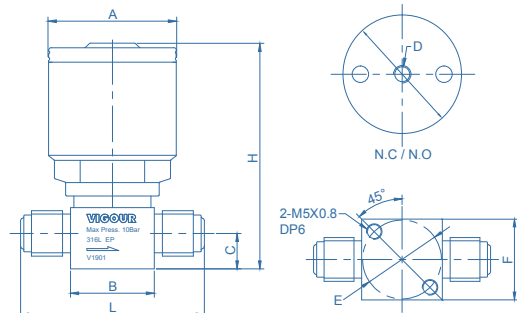

1/4 pneumatic actuator (VFS male)

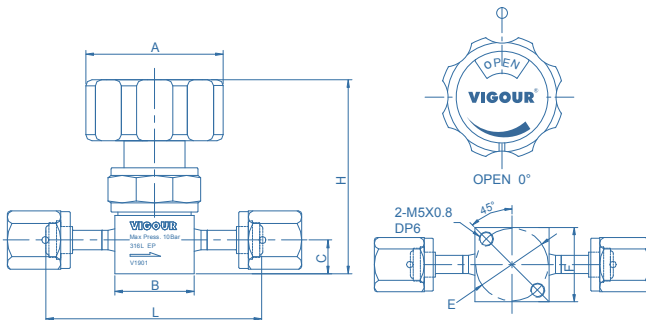

1/4, 1/2, 3/4 manual actuator (VFS female)

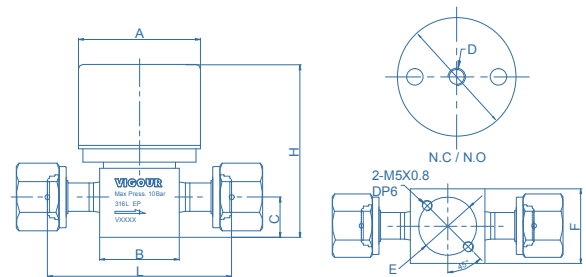

1/2 pneumatic actuator (VFS female)

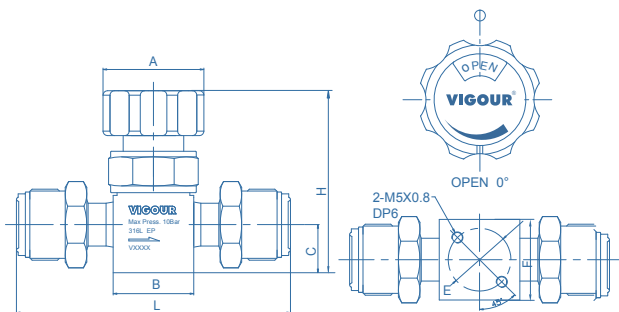

3/4 manual actuator (VFS male)

manual actuator

| End Connections | Orifice (mm) | Dimensions (mm) | | | | | | | |
|-----------------|--------------|-----------------|----|------|-------|----|-------|----|--|
| | | A | B | C | E | F | L | H | |
| 1/4" VFS male | 4.4 | Φ45 | 26 | 11 | Φ25.4 | 26 | 57 | 64 | |
| 1/4" VFS female | 4.4 | Φ45 | 26 | 11 | Φ25.4 | 26 | 71 | 64 | |
| 3/8" VFS male | 7 | Φ45 | 36 | 18.2 | Φ28 | 36 | 77 | 78 | |
| 1/2" VFS male | 7 | Φ45 | 36 | 18.2 | Φ28 | 36 | 77 | 78 | |
| 1/2" VFS female | 7 | Φ45 | 36 | 18.2 | Φ28 | 36 | 83 | 78 | |
| 3/4" VFS male | 7 | Φ45 | 36 | 21.5 | Φ28 | 36 | 122.3 | 82 | |
| 3/4" VFS female | 7 | Φ45 | 36 | 21.5 | Φ28 | 36 | 106.3 | 82 | |

pneumatic actuator, normally opened / normally closed

| End Connections | Actuator | Orifice (mm) | Dimensions (mm) | | | | | | | |
|-----------------|-----------|--------------|-----------------|----|------|---------|-------|----|----|----|
| | | | A | B | C | D | E | F | L | H |
| 1/4" VFS male | N.C / N.O | 4.4 | Φ39.6 | 26 | 11 | M5x0.8 | Φ25.4 | 26 | 57 | 70 |
| 1/4" VFS female | N.C / N.O | 4.4 | Φ39.6 | 26 | 11 | M5x0.8 | Φ25.4 | 26 | 71 | 70 |
| 3/8" VFS male | N.C / N.O | 7 | Φ55 | 36 | 18.2 | RC 1/8" | Φ28 | 36 | 77 | 78 |
| 1/2" VFS male | N.C / N.O | 7 | Φ55 | 36 | 18.2 | RC 1/8" | Φ28 | 36 | 77 | 78 |
| 1/2" VFS female | N.C / N.O | 7 | Φ55 | 36 | 18.2 | RC 1/8" | Φ28 | 36 | 83 | 78 |

Ordering information

VDV32UBS - M - A - MV4 - MV4 - PA — Valve Seat Option

Materials

S: 316L
SLV: 316L secondary remelt

Actuator

M: manual actuator
PO: pneumatic actuator, normally opened
PC: pneumatic actuator, normally closed

Flow Circuit Diagram

For details, please visit the attached table P52: flow circuit diagram.

None: PCTFE(standard)
VS: Vespel®
PA: PFA

End Connection

MV4: 1/4" VFS male
FV4: 1/4" VFS female
TW4: 1/4" tube weld
MV6: 1/2" VFS male 3/8" O.D.
FV6: 1/2" VFS female 3/8" O.D.
TW6: 3/8" tube weld
MV8: 1/2" VFS male
FV8: 1/2" VFS female
TW8: 1/2" tube weld
MV12: 3/4" VFS male

* Other connection standard, consult factory

Diaphragm Valves

VDV33UB Series

Product Feature

- Suitable for ultra pure, flammable or toxic fluid lines in semiconductor manufacturing equipment and facilities
- Direct diaphragm construction with superior sealing performance, remarkable durability, compactness and particle and dead-space-free performance
- Valve open and closed option is easily visible at a glance
- Excellent gas displacement characteristics
- EP treatment is standard for all wetted surfaces
- Standard seat material is PEEK, Polyimide/PFA is option

Temperature / Pressure Rating

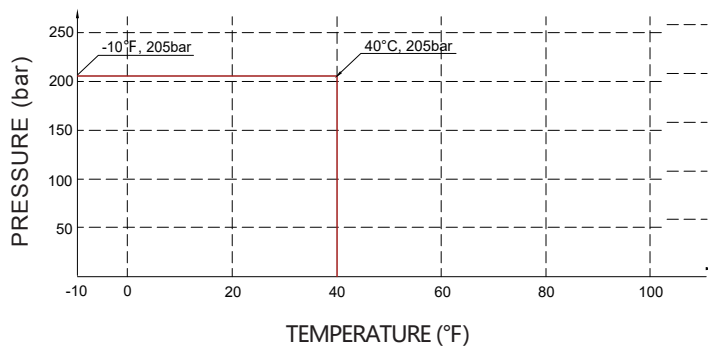

1/4 Type



1/4 Type



1/2 Type



1/2 Type

Technical Data

| | |
|-------------------------------|--|
| Max. Working Pressure: | 3000 psig (206 bar) |
| Pneumatic Operating Pressure: | 58~87psig (4-6bar) |
| Max. Working Temp.: | -10°F ~ 150°F (-23°C ~ 65°C) |
| Surface finish: | 10µin. Ra |
| Materials | |
| Body: | see ordering info |
| Diaphragm: | Elgiloy® |
| Seat packing: | PEEK |
| Handle: | AL |
| Internal Leakage Allowance: | 1x10 ⁻⁹ mbar l/s He |
| External Leakage Allowance: | 1x10 ⁻⁹ mbar l/s He |
| Flow capacity: | 1/4" Cv=0.1 3/8" 1/2" Cv=0.5 |
| Weight: | approx. 0.27kg (actuator not included) |

Dimensions (mm)

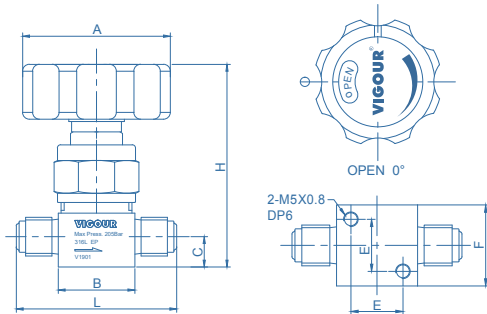

1/4 manual actuator (VFS male)

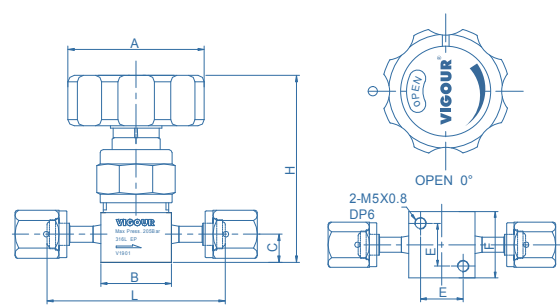

1/4 manual actuator (VFS female)

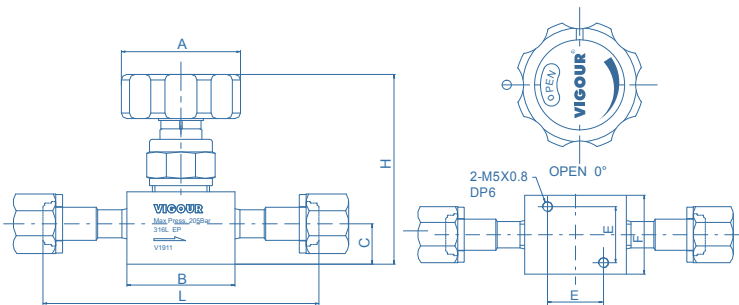

1/2 manual actuator (VFS female)

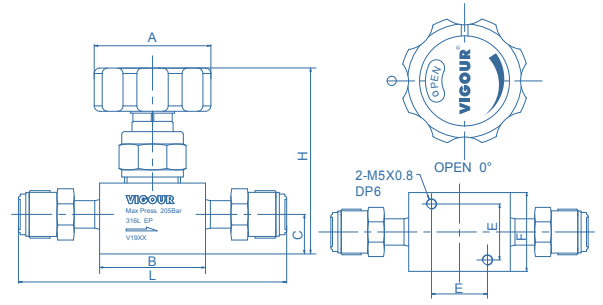

3/8, 1/2 manual actuator (VFS male)

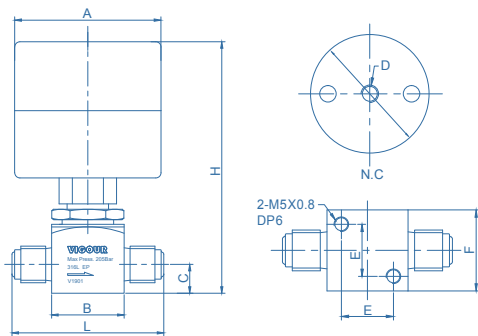

1/4 pneumatic actuator N.C. (VFS male)

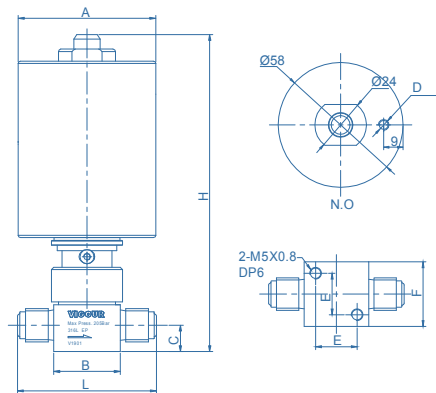

1/4 pneumatic actuator N.O. (VFS male)

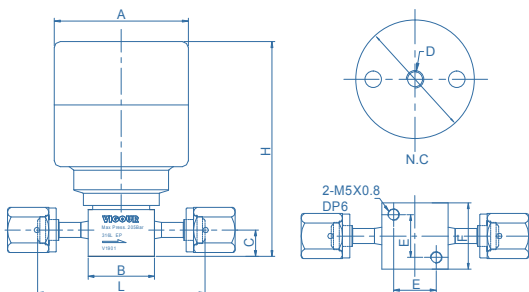

1/4 pneumatic actuator N.C. (VFS female)

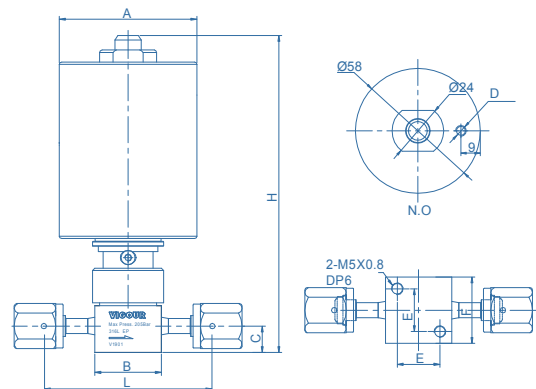

1/4 pneumatic actuator N.O. (VFS female)

Diaphragm Valves

VDV33UB Series

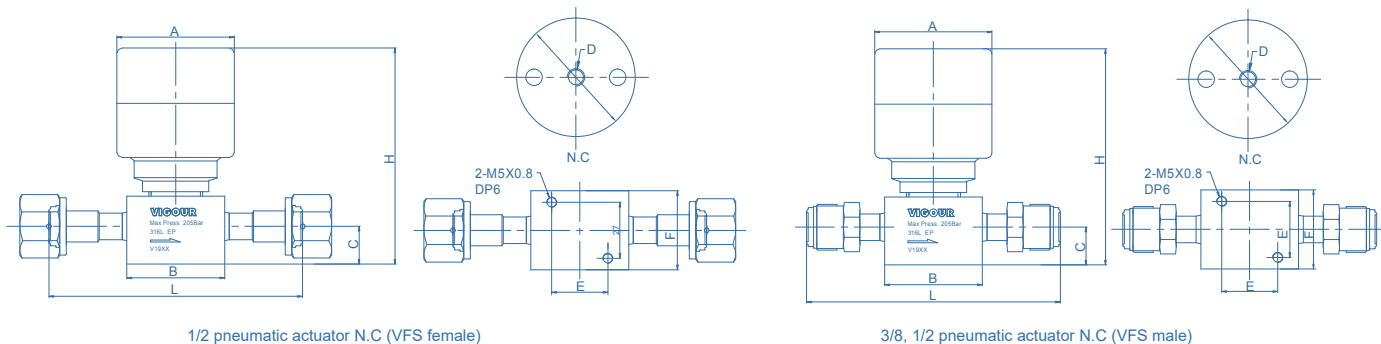

manual actuator

| End Connections | Orifice (mm) | Dimensions (mm) | | | | | | |
|-----------------|--------------|-----------------|------|------|----|----|-------|----|
| | | A | B | C | E | F | L | H |
| 1/4" VFS male | 4.4 | Φ54 | 28 | 11.1 | 18 | 28 | 58.6 | 74 |
| 1/4" VFS female | 4.4 | Φ54 | 28 | 11.1 | 18 | 28 | 71.6 | 74 |
| 3/8" VFS male | 7 | Φ54 | 47.1 | 18.2 | 27 | 38 | 123.2 | 86 |
| 1/2" VFS male | 7 | Φ54 | 47.1 | 18.2 | 27 | 38 | 123.2 | 86 |
| 1/2" VFS female | 7 | Φ54 | 47.1 | 18.2 | 27 | 38 | 123.2 | 86 |

pneumatic actuator, normally opened / normally closed

| End Connections | Actuator | Orifice (mm) | Dimensions (mm) | | | | | | | |
|-----------------|----------|--------------|-----------------|------|------|--------|----|----|-------|------|
| | | | A | B | C | D | E | F | L | H |
| 1/4" VFS male | N.C | 4.4 | Φ56.5 | 28 | 11.1 | M5x0.8 | 18 | 28 | 58.6 | 90.5 |
| 1/4" VFS male | N.O | 4.4 | Φ58 | 28 | 11.1 | M5x0.8 | 18 | 28 | 58.6 | 134 |
| 1/4" VFS female | N.C | 4.4 | Φ56.5 | 28 | 11.1 | M5x0.8 | 18 | 28 | 71.6 | 90.5 |
| 1/4" VFS female | N.O | 4.4 | Φ58 | 28 | 11.1 | M5x0.8 | 18 | 28 | 71.6 | 134 |
| 3/8" VFS male | N.C | 7 | Φ56.5 | 47.1 | 18.2 | M5x0.8 | 27 | 38 | 123.2 | 105 |
| 1/2" VFS male | N.C | 7 | Φ56.5 | 47.1 | 18.2 | M5x0.8 | 27 | 38 | 123.2 | 105 |
| 1/2" VFS female | N.C | 7 | Φ56.5 | 47.1 | 18.2 | M5x0.8 | 27 | 38 | 123.2 | 105 |

1/4", 3/8", 1/2" VFS fitting dimensions for reference, other connections please contact factory.

Ordering Information

VDV33UBS - M - A - MV4 - MV4 - PA

Materials

S: 316L
SLV: 316L secondary remelt

Actuator

M: manual actuator
PO: pneumatic actuator, normally opened *
PC: pneumatic actuator, normally closed

* Normally opened available with connection size 1/4 thch.

Flow Circuit Diagram

For details, please visit the attached table P52: flow circuit diagram.

Valve Seat Option

None: PEEK(standard)
VS: Vespel®
PA: PFA

End Connection

MV4: 1/4" VFS male
FV4: 1/4" VFS female
TW4: 1/4" tube weld
MV6: 1/2" VFS male 3/8" O.D.
FV6: 1/2" VFS female 3/8" O.D.
TW6: 3/8" tube weld
MV8: 1/2" VFS male
FV8: 1/2" VFS female
TW8: 1/2" tube weld

* Other connection standard, consult factory

Product Feature

- Suitable for ultra pure, flammable or toxic fluid lines in semiconductor manufacturing equipment and facilities
- Direct diaphragm construction with superior sealing performance, remarkable durability, compactness and particle and dead-space-free performance
- Valve open and closed option is easily visible at a glance
- Excellent gas displacement characteristics
- EP treatment is standard for all wetted surfaces
- Standard seat material is PCTFE, Polyimide/PFA is option

Temperature / Pressure Rating

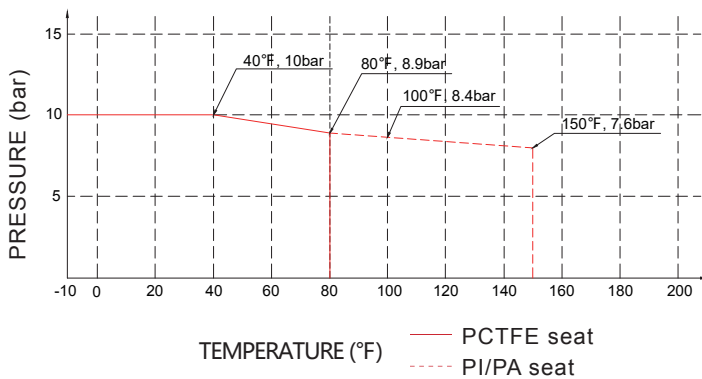

1/4 Type



1/4 Type



1/2 Type



1/2 Type

Technical Data

| | |
|-------------------------------|--|
| Max. Working Pressure: | 300 psig (20 bar) |
| Pneumatic Operating Pressure: | 58~87psig (4-6bar) |
| Max. Working Temp.: | -10°F ~ 150°F (-23°C ~ 65°C) |
| Surface finish: | 10µin. Ra |
| Materials | |
| Body: | see ordering info |
| Diaphragm: | Elgiloy® |
| Seat packing: | PCTFE |
| Handle: | AL |
| Internal Leakage Allowance: | 1x10 ⁻⁹ mbar l/s He |
| External Leakage Allowance: | 1x10 ⁻⁹ mbar l/s He |
| Flow capacity: | Cv=0.3 (Cv=0.65 option) |
| Weight: | approx. 0.27kg (actuator not included) |

Diaphragm Valves

VDV52 Series

Dimensions (mm)

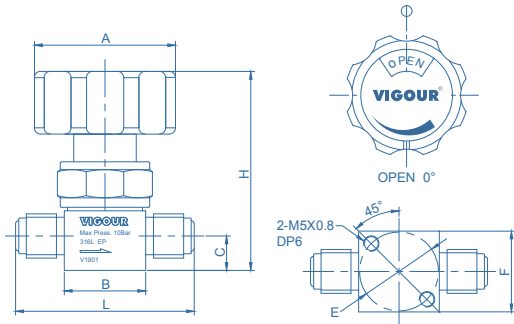

1/4, 3/8, 1/2 manual actuator (VFS male)

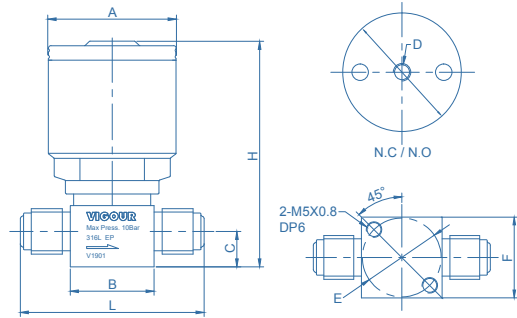

1/4 pneumatic actuator (VFS male)

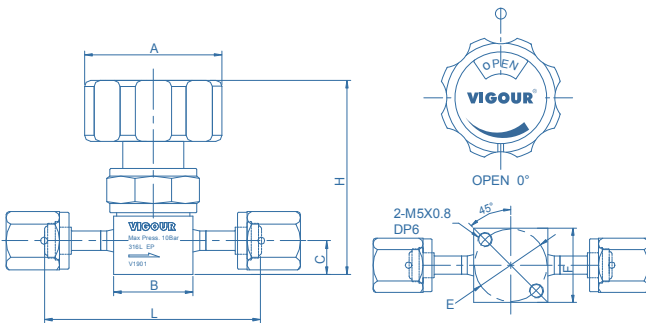

1/4, 1/2 manual actuator (VFS female)

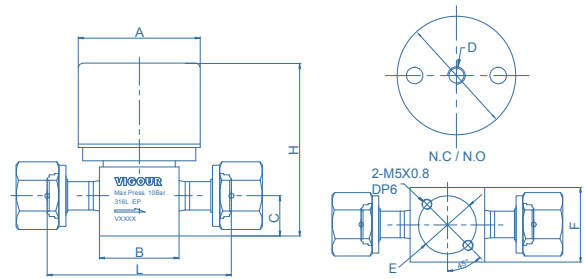

1/2 pneumatic actuator (VFS female)

manual actuator

| End Connections | Orifice (mm) | Dimensions (mm) | | | | | | |
|-----------------|--------------|-----------------|----|------|-------|----|----|----|
| | | A | B | C | E | F | L | H |
| 1/4" VFS male | 4.4 | Φ45 | 26 | 11 | Φ25.4 | 26 | 57 | 64 |
| 1/4" VFS female | 4.4 | Φ45 | 26 | 11 | Φ25.4 | 26 | 71 | 64 |
| 3/8" VFS male | 7 | Φ45 | 36 | 18.2 | Φ28 | 36 | 77 | 78 |
| 1/2" VFS male | 7 | Φ45 | 36 | 18.2 | Φ28 | 36 | 77 | 78 |
| 1/2" VFS female | 7 | Φ45 | 36 | 18.2 | Φ28 | 36 | 83 | 78 |

pneumatic actuator, normally opened / normally closed

| End Connections | Actuator | Orifice (mm) | Dimensions (mm) | | | | | | | |
|-----------------|-----------|--------------|-----------------|----|------|--------|-------|----|----|----|
| | | | A | B | C | D | E | F | L | H |
| 1/4" VFS male | N.C / N.O | 4.4 | Φ39.6 | 26 | 11 | M5x0.8 | Φ25.4 | 26 | 57 | 70 |
| 1/4" VFS female | N.C / N.O | 4.4 | Φ39.6 | 26 | 11 | M5x0.8 | Φ25.4 | 26 | 71 | 70 |
| 3/8" VFS male | N.C / N.O | 7 | Φ55 | 36 | 18.2 | RC 1/8 | Φ28 | 36 | 77 | 78 |
| 1/2" VFS male | N.C / N.O | 7 | Φ55 | 36 | 18.2 | RC 1/8 | Φ28 | 36 | 77 | 78 |
| 1/2" VFS female | N.C / N.O | 7 | Φ55 | 36 | 18.2 | RC 1/8 | Φ28 | 36 | 83 | 78 |

Ordering information

VDV52 S - M - A - MV4 - MV4 - PA

Materials

S: 316L
SLV: 316L secondary remelt

Actuator

M: manual actuator
PO: pneumatic actuator, normally opened
PC: pneumatic actuator, normally closed

Flow Circuit Diagram

For details, please visit the attached table P52: flow circuit diagram.

Valve Seat Option

None: PCTFE(standard)
VS: Vespel®
PA: PFA

End Connection

MV4: 1/4" VFS male
FV4: 1/4" VFS female
TW4: 1/4" tube weld
MV6: 1/2" VFS male 3/8" O.D.
FV6: 1/2" VFS female 3/8" O.D.
TW6: 3/8" tube weld
MV8: 1/2" VFS male
FV8: 1/2" VFS female
TW8: 1/2" tube weld

* Other connection standard, consult factory

Ports Diagrammatic Drawing:

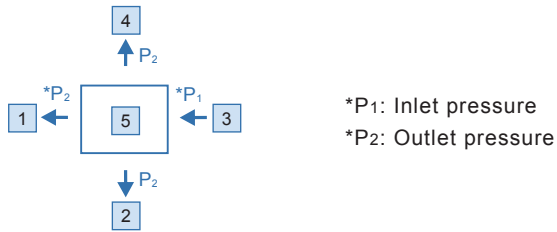

Two ports flow circuit diagram:

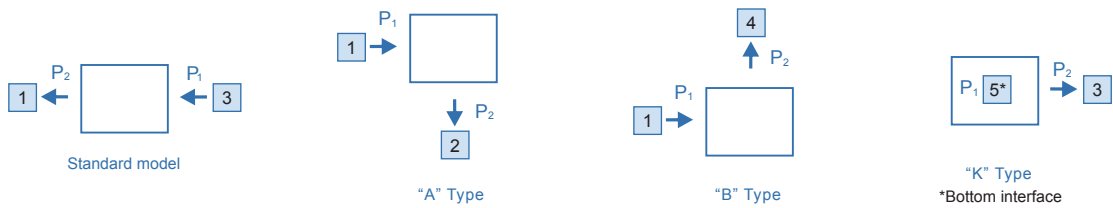

Three ports flow circuit diagram:

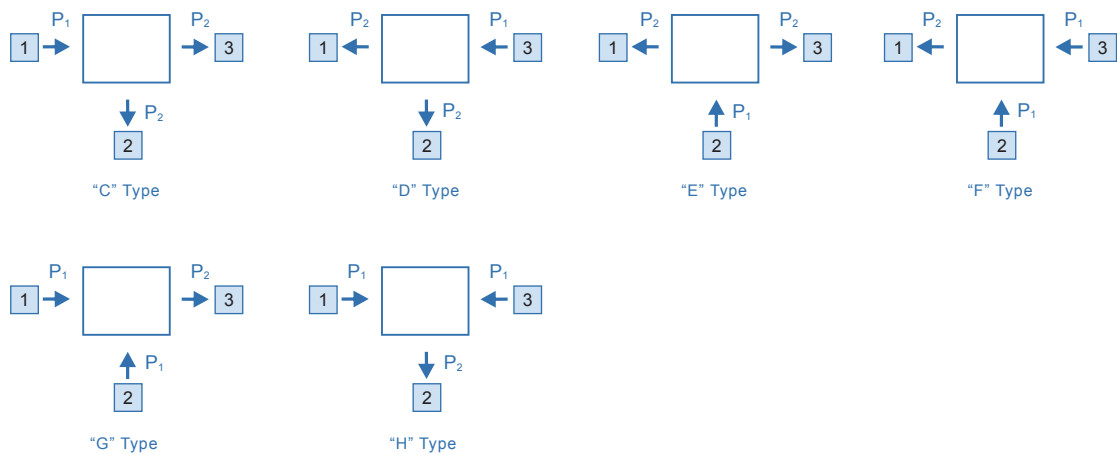

Four ports flow circuit diagram:

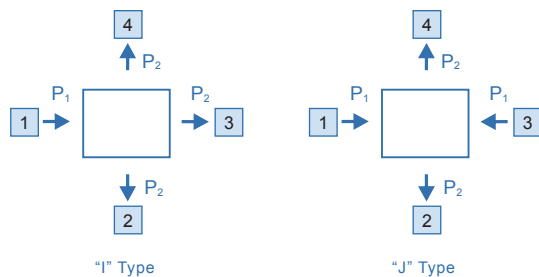

Low-pressure Diaphragm Valve Manifold VDV36 Series

Product Feature

- Excellent degassing characteristics is achieved through minimized flow paths by combining 2 of VDV32、VDV33 diaphragm valves together in one valve body.
- Fewer welds over standard valve alignments
- Reduces space requirements
- Compact tubing arrangement
- Dead space free configuration



Dimensions (mm)

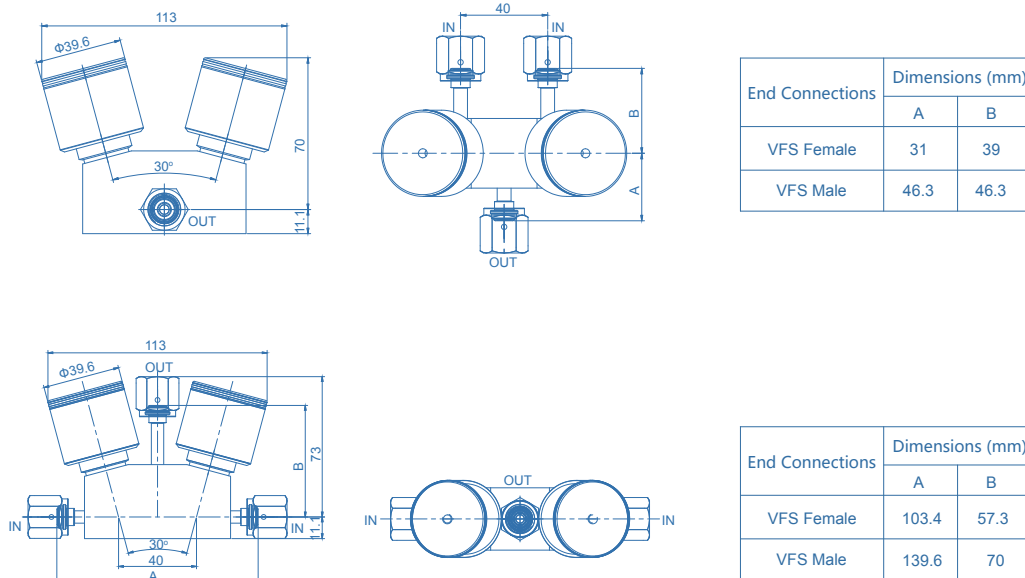

Technical Data

| | |
|-------------------------------|---|
| Max. Working Pressure: | 150 psig (10 bar) 3000 psig (206bar) optional |
| Pneumatic Operating Pressure: | 58~87psig (4-6bar) |
| Max. Working Temp.: | -10°F ~ 150°F (-23°C ~ 65°C) |
| Surface finish: | 10µin. Ra |
| Materials | |
| Body: | see ordering info |
| Diaphragm: | Elgiloy® |
| Seat packing: | PCTFE |
| Handle: | AL |
| Internal Leakage Allowance: | 1x10 ⁻⁹ mbar l/s He |
| External Leakage Allowance: | 1x10 ⁻⁹ mbar l/s He |
| Flow capacity: | Cv=0.23 (Cv=0.1 optional) |
| Weight: | approx. 0.27kg (actuator not included) |

Low-pressure Diaphragm Valve Manifold VDV36 Series

Ordering information

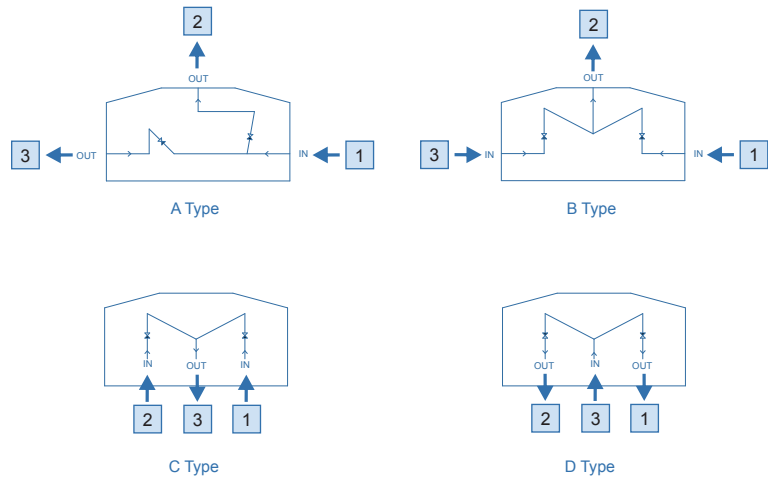

Inlet/Outlet Connexion

MV4: 1/4" VFS male
FV4: 1/4" VFS female
TW4: 1/4" tube weld

MV6: 1/2" VFS male 3/8" O.D.
FV6: 1/2" VFS female 3/8" O.D.
TW6: 3/8" tube weld

MV8: 1/2" VFS male
FV8: 1/2" VFS female
TW8: 1/2" tube weld

* Other connection standard, consult factory.

Port Selection

VDV36 S - A - H - M - PC - 1 - 2 - 3

Materials

S: 316L EP
SLV: 316L secondary remelt

Flow Rate

A: A Type
B: B Type
C: C Type
D: D Type

Working Pressure

None: 150 psig
H: 3000 psig

Valve2 Actuator*

M: manual actuator
PO: pneumatic actuator, normally opened
PC: pneumatic actuator, normally closed

* When the actuators are the same there will be one symbol.

Valve1 Actuator

M: manual actuator
PO: pneumatic actuator, normally opened
PC: pneumatic actuator, normally closed

Ordering Example

Example: VDV36S - A - M - PC - FV4 - FV4 - FV4

1 - 2 - 3



Metering Valves

VMV Series

Product Features

- Low pressure metering valves
- Body materials: 316 / Brass
- Panel installation is possible
- Vernier handles Options
- Straight and Angle flow patterns
- Working pressure: Max. 2000psig (137bar)
- Straight-pattern flow coefficients (Cv) from 0.004 to 0.16

Technical Data

| Series | Pressure-Temperature Ratings | | Orifice in. (mm) | Shutoff Service | Stem Taper (Included Angle) |
|--------|--------------------------------------|----------------------|------------------|------------------|-----------------------------|
| | Temperature °C | Working Pressure bar | | | |
| A type | -23°C to +204°C (FKM O-rings) | 137 | 0.032 (0.81) | No | 1° |
| B type | | | 0.056 (1.42) | No | 3° |
| C type | -23°C to +148°C (Buna N, O-rings) | 68.9 ^① | 0.128 (3.25) | Yes ^② | 6° |

① Downstream pressure 500 psig (34.4 bar) max when valve requires adjustment at pressure due to strength limitations of the fine-pitch threads and high operating torque.

② Stainless steel L series valves are not recommended for shutoff in vacuum or gas service, or for repetitive shutoff in liquid service.



Flow Coefficient at Turns Open

Flow Data at 70°F (20°C)

A type Metering Valves

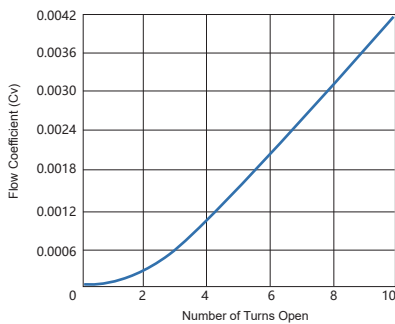

B type Metering Valves

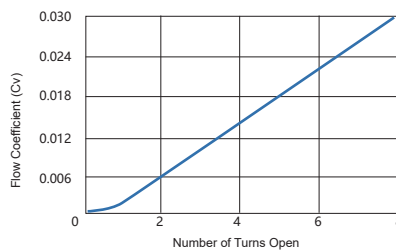

C type Metering Valves

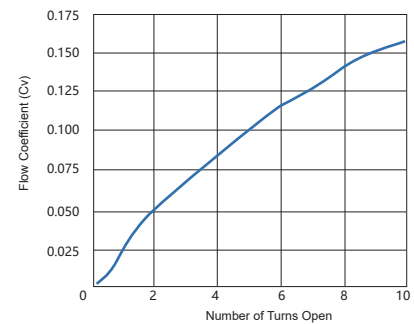

| Max. Flow Cv=0.004 | |
|---------------------------------|--------------------|
| Pressure Drop to Atmosphere bar | Air Flow std L/min |
| 0.68 | 1.1 |
| 3.4 | 2.8 |
| 6.8 | 5.6 |

| Max. Flow Cv=0.03 | |
|---------------------------------|--------------------|
| Pressure Drop to Atmosphere bar | Air Flow std L/min |
| 0.68 | 9.3 |
| 3.4 | 25.4 |
| 6.8 | 42.4 |

| Max. Flow Cv=0.16 | |
|---------------------------------|--------------------|
| Pressure Drop to Atmosphere bar | Air Flow std L/min |
| 0.68 | 56.6 |
| 3.4 | 181 |
| 6.8 | 323 |

Dimensions

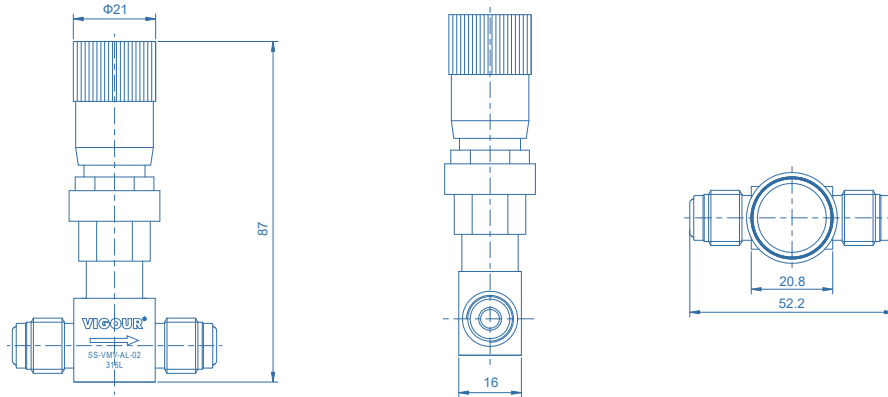

| End Connections | | Ordering Number | Dimensions, in. (mm) | | | | | |
|---------------------------|----------|-----------------|----------------------|-------------|-------------|-------------|-------------|-------------|
| Inlet/Outlet | Size | | L | H | H1 | H2 | E | G |
| A type (Straight Pattern) | | | | | | | | |
| Tube Fittings | 1/16 in. | SS-VNV-A-01 | 1.56 (39.6) | 2.34 (59.4) | 0.92 (23.4) | / | 0.38 (9.6) | 0.45 (11.4) |
| | 1/8 in. | SS-VMV-A-02 | 1.90 (48.3) | | | | | |
| | 1/4 in. | SS-VMV-A-04 | 2.04 (51.8) | | | | | |
| | 3mm | SS-VMV-A-3M | 1.90 (48.3) | | | | | |
| | 6mm | SS-VMV-A-6M | 2.04 (51.8) | | | | | |
| VFS Male | 1/4 in. | SS-VMV-A-MV4 | 2.06 (52.3) | | | | | |
| A type (Angle Pattern) | | | | | | | | |
| Tube Fittings | 1/16 in. | SS-VMV-AL-01 | 0.81 (20.6) | 3.22 (81.8) | 0.92 (23.4) | 0.88 (22.4) | 0.38 (9.6) | 0.45 (11.4) |
| | 1/8 in. | SS-VMV-AL-02 | 0.98 (24.9) | 3.22 (81.8) | | 0.98 (24.9) | | |
| | 1/4 in. | SS-VMV-AL-04 | 1.02 (25.9) | 3.36 (85.3) | | 1.02 (25.9) | | |
| | 3mm | SS-VMV-AL-3M | 0.98 (24.9) | 3.32 (84.3) | | 0.99 (25.1) | | |
| Male NPT / Tube Fittings | 1/8 in. | SS-VMV-AL-M2-02 | 0.98 (24.9) | 3.07 (78.0) | | 0.98 (24.9) | | |
| B type (Straight Pattern) | | | | | | | | |
| Tube Fittings | 1/8 in. | SS-VMV-B-02 | 2.02 (51.3) | 2.78 (70.6) | 1.56 (39.6) | / | 0.50 (12.7) | 0.58 (14.7) |
| | 1/4 in. | SS-VMV-B-04 | 2.20 (55.9) | | | | | |
| | 3mm | SS-VMV-B-3M | 2.02 (51.3) | | | | | |
| | 6mm | SS-VMV-B-6M | 2.20 (55.9) | | | | | |
| Male NPT | 1/8 in. | SS-VMV-B-M2 | 1.50 (38.1) | | | | | |
| | 1/4 in. | SS-VMV-B-M4 | 1.96 (49.8) | | | | | |
| Female NPT | 1/8 in. | SS-VMV-B-F2 | 1.94 (49.3) | | | | | |
| VFS Male | 1/4 in. | SS-VMV-B-MV4 | 2.06 (52.3) | | | | | |
| B type (Angle Pattern) | | | | | | | | |
| Tube Fittings | 1/8 in. | SS-VMV-BL-02 | 1.01 (25.7) | 3.30 (83.8) | 1.07 (27.2) | 1.01 (25.7) | 0.50 (12.7) | 0.58 (14.7) |
| | 1/4 in. | SS-VMV-BL-04 | 1.10 (27.9) | 3.39 (86.1) | | 1.10 (27.9) | | |
| | 3mm | SS-VMV-BL-3M | 1.01 (25.7) | 3.30 (83.8) | | 1.01 (25.7) | | |
| | 6mm | SS-VMV-BL-6M | 1.10 (27.9) | 3.39 (86.1) | | 1.10 (27.9) | | |
| Male NPT | 1/8 in. | SS-VMV-BL-M2 | 0.75 (19.1) | 3.04 (77.2) | | 0.75 (19.1) | | |
| | 1/4 in. | SS-VMV-BL-M4 | 0.98 (24.9) | 3.27 (83.1) | | 1.02 (25.9) | | |
| Male NPT / Tube Fittings | 1/8 in. | SS-VMV-BL-M2-02 | 1.01 (25.7) | 3.04 (77.2) | | 0.75 (19.1) | | |
| Female NPT | 1/8 in. | SS-VMV-BL-F2 | 0.97 (24.6) | 3.26 (82.8) | | 0.97 (24.6) | | |

Metering Valves

VMV Series

Dimensions

| End Connections | | Ordering Number | Dimensions, in. (mm) | | | | | |
|---------------------------|---------|-----------------|----------------------|-------------|-------------|-------------|-------------|-------------|
| Inlet/Outlet | Size | | L | H | H1 | H2 | E | G |
| C type (Straight Pattern) | | | | | | | | |
| Tube Fittings | 1/4 in. | SS-VMV-C-04 | 2.34 (59.4) | 2.82 (71.6) | 1.26 (32.0) | / | 1.13 (28.7) | 0.58 (14.7) |
| | 3/8 in. | SS-VMV-C-06 | 2.46 (62.5) | | | | | |
| | 6mm | SS-VMV-C-6M | 2.34 (59.4) | | | | | |
| Male NPT | 1/4 in. | SS-VMV-C-M4 | 2.00 (50.8) | | | | | |
| C type (Angle Pattern) | | | | | | | | |
| Tube Fittings | 1/4 in. | SS-VMV-CL-04 | 1.17 (29.7) | 3.77 (95.8) | 1.04 (26.4) | 1.17 (29.7) | 1.13 (28.7) | 0.58 (14.7) |
| | 6mm | SS-VMV-CL-6M | | | | | | |

Options and Accessories



Vernier Handle

Product Features:

- Helps ensure repeatable flow adjustments.
- Provides readings accurate to 1/25 turn.
- Kits contain all parts necessary to add a vernier handle to an existing valve.

Ordering Example:

SS-VMV-AL-02-Y

Ordering Information

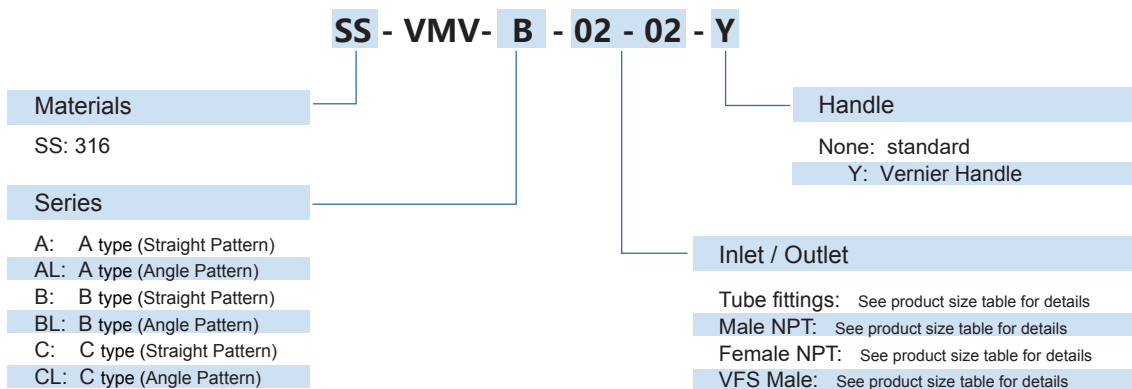

All-Welded Check Valves VUCV Series

Product Feature

- All-welded design body with minimal dead space
- Cracking pressure less than 2 psig
- 316L SS Materials for ultra high purity grade
- Strong durability as well as corrosion resistance for long cycle life
- Elgiloy® spring material with free noise in the process of useny



Technical Data

| | |
|----------------------|----------------|
| Working Pressure: | 3000 psig |
| Cracking Pressure: | <2 psig |
| Working Temperature: | -10~80°C |
| Material | |
| Body: | SS 316L |
| Spring: | Elgiloy® |
| O-ring: | FKM |
| Flow Capacity: | Cv=0.55 (1/4") |
| | Cv=0.70 (1/2") |

Dimensions (mm)

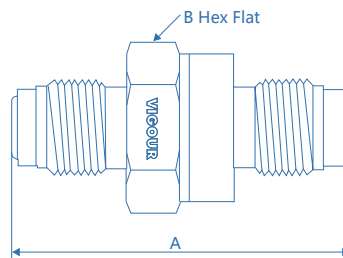

| End Cconnections | Dimensions (mm) | |
|------------------|-----------------|----|
| | A | B |
| 1/4" VFS male | 45.7 | 22 |
| 1/2" VFS male | 52.5 | 27 |

Ordering Information

VUCV - S - MV4 - MV4 - E

Material

S: 316L

Inlets / Outlets

MV4: 1/4" VFS male
MV8: 1/2" VFS male

Seal Materials

E: EPDM

K: Kalrez® (FFKM)

Check Valves VCVH Series

Product Feature

- Compact check valve
- O-ring Materials: VITON® standard, EPDM optional
- working pressure: Max. 300bar
- Opening pressure: 1/3psi / 1psi
- Inlet/outlet connection: NPT thread / NPT tube fitting



Typical Applications

- Designed for instrument panels and systems
- Hydrogen energy
- High-flow applications

Technical Data

| | |
|--------------------------|--------------------------------------|
| Working pressure: | Max. 300 bar |
| Opening pressure: | 1/3psi / 1psi |
| Parent material: | see ordering info |
| Inlet/outlet connection: | see ordering info |
| O-ring: | VITON® (standard) EPDM (optional) |
| Leakage rate: | Bubble-tight |

| Minimum open reset pressure | | Reset pressure |
|-----------------------------|-----------------|----------------|
| psi(bar) | | |
| 1/3 (0.03) | 3 (0.21) under | 6 (0.42) under |
| 1 (0.07) | 4 (0.28) under | 5 (0.35) |
| 5 (0.35) | 3~9 (0.21~0.63) | 2 (0.14) |
| 10 (0.69) | 7~15 (0.49~1.1) | 3 (0.21) |
| 25 (1.8) | 20~30 (1.4~2.1) | 17 (1.21) |

Flow Chart

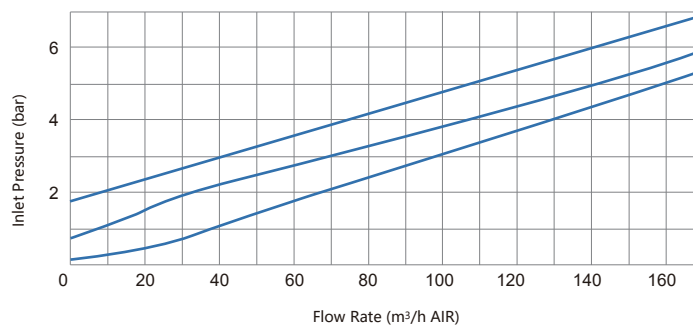
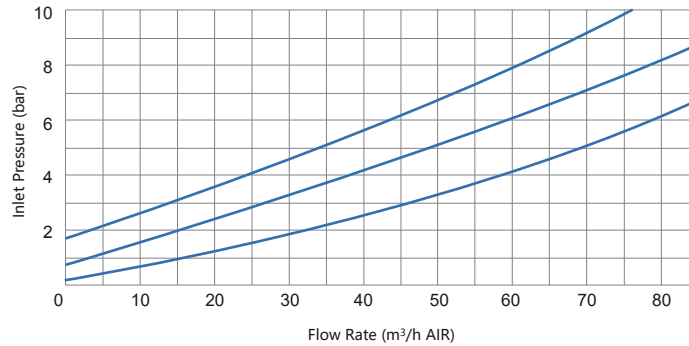

Dimensions (mm)

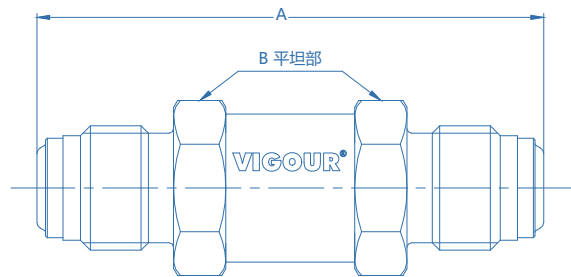

| Ordering Number | Dimensions (mm) | |
|-----------------|-----------------|------|
| | A | B |
| VCVH-S-MV4-MV4 | 58.2 | 17.4 |
| VCVH-S-MV8-MV8 | 68.3 | 25.4 |

Ordering Information

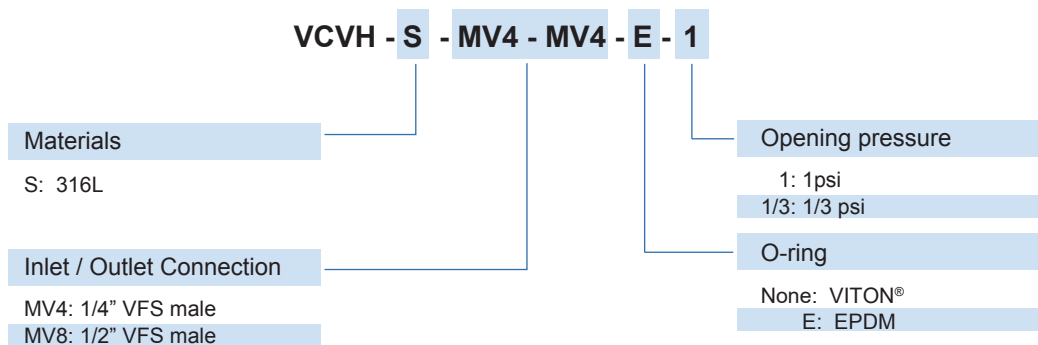

Bellows Valves

VUBV Series

Product Feature

- 316L stainless steel construction
- Tube fitting, tube welding, and VFS fitting joints
- Easy to clean to keep operation clean
- Excellent gas displacement characteristics
- EP treatment is standard for all wetted surfaces
- Standard seat material is PCTFE, Polyimide is option
- All-metal seal to atmosphere



Flowchart

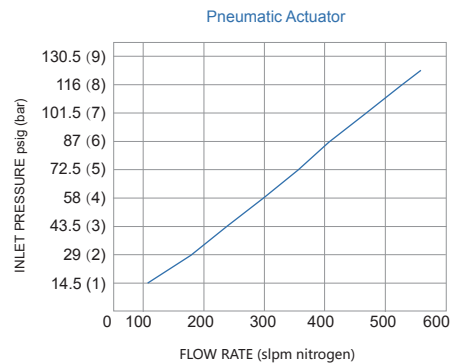
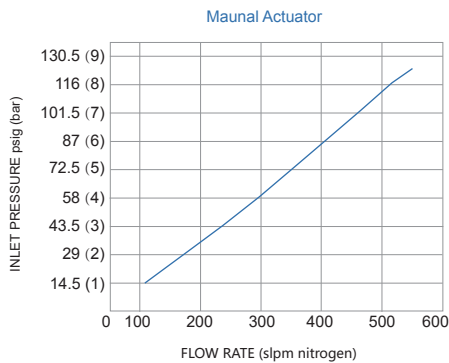

Technical Data

| | |
|-----------------------------|---|
| Manual Pressure: | Vacuum 500 psig (35bar) |
| Pneumatic Pressure: | Vacuum 125 psig (8.6bar) |
| Operating Pressure: | 45~120 psig (3.2~8.2bar) |
| Surface finish: | 10µin. Ra Standard (7µin. Ra / 5µin. Ra optional) |
| Working Temp.: | -40°F ~ 200°F (-40°C ~ 93°C) |
| Materials | |
| Body: | 316L |
| Bellows: | A269 / A240 stainless steel |
| Seat packing: | PCTFE |
| Handle: | AL |
| Internal Leakage Allowance: | 4x10 ⁻⁹ mbar l/s He |
| External Leakage Allowance: | 4x10 ⁻⁹ mbar l/s He |
| Flow capacity: | Cv=0.3 |
| Weight: | approx. 1.54kg (actuator not included) |

Dimensions (mm)

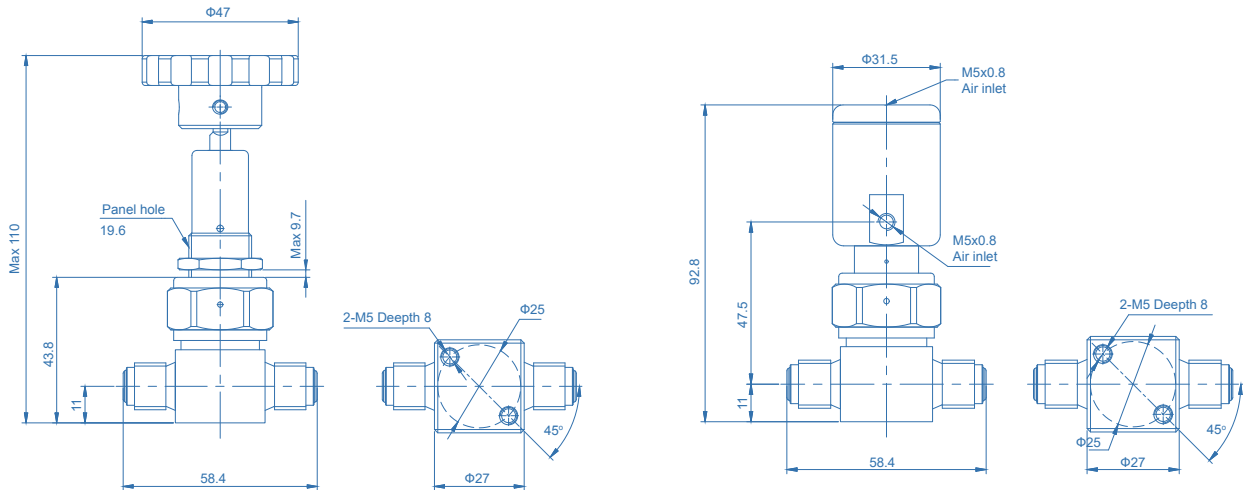

Ordering Information

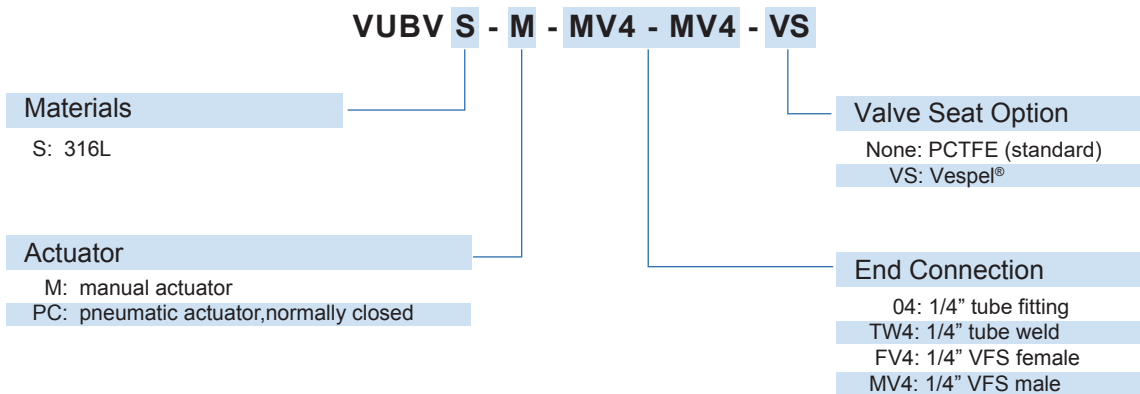

* Other connection standard, consult factory

* Tube fitting wetted surface Ra. 20µm machine finished, TW4, FV4, MV4 wetted surface Ra. 8µm machine finished and electropolished

Vacuum Generators

VVG Series

Product Feature

- Max. vacuum pressure: -90kPa
- Stainless steel 316L construction
- MMHG (Torr) vacuum generators
- With a minimum source nitrogen pressure of 90 psig
- 100% helium leak test



Dimensions (mm)

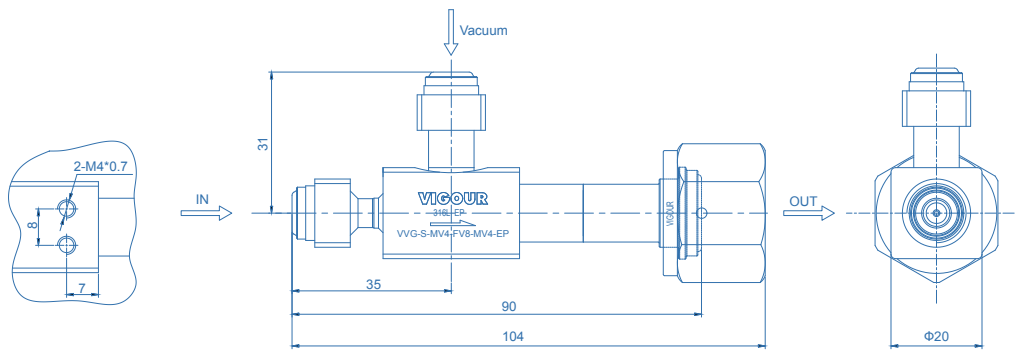

Technical Data

| | |
|---|-------------------|
| Type: | Vacuum Generators |
| Max. Vacuum pressure: | -90kPa |
| Inlet pressure at limiting vacuum pressure: | 5 bar |
| Flow at limiting vacuum pressure: | 37L/min |
| Body Material: | SS 316L |
| Max. Working pressure: | 10 bar |
| Temperature range: | 0~150°C |
| Source Gas: | Nitrogen |

Vacuum and Flow Specification

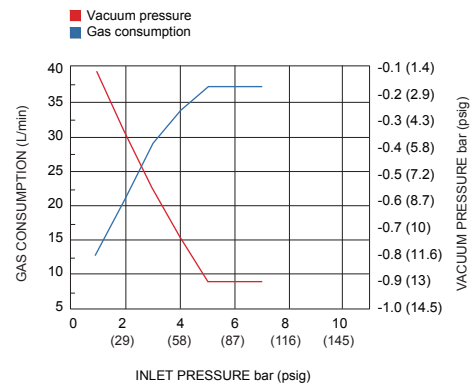

Ordering Information

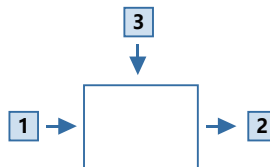
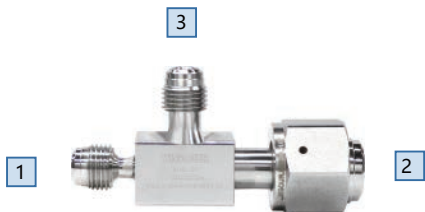

Inlet/Outlet Connecion

| | |
|----------------------|--------------------|
| FV4: 1/4" VFS female | MV4: 1/4" VFS male |
| FV8: 1/2" VFS female | MV8: 1/2" VFS male |

* Other connection standard, consult factory.

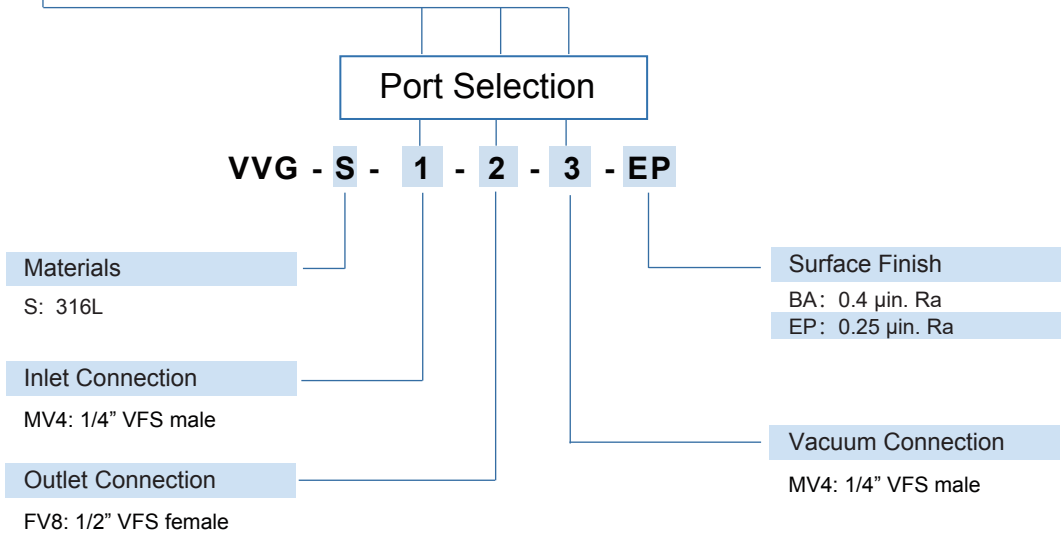

Ordering Example

Example: VVG - S - MV4 - FV8 - MV4

1 - 2 - 3

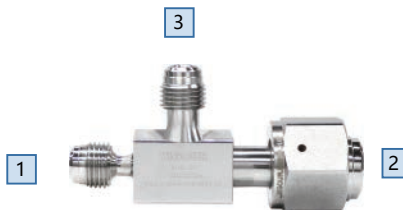

Gas Stick Assemblies

VUP Series

Product Features

- Ultra high purity gas stick for all gas delivery systems
 - 100TG: ≤30 slpm delivery 1/4" VFS
 - 200TG: ≤300 slpm delivery 3/8" VFS
 - 300TG: ≤600 slpm delivery 1/2" VFS
- High control accuracy
- All connections welded or VFS
- Manual or pneumatic diaphragm valve option
- 100% Helium-leak-tested

Technical Data

| | |
|----------------------------|--------------------------------|
| Inlet pressure P1: | 300 psig |
| Outlet pressure P2: | 30/60/100/150 psig |
| Diaphragm valve materials | |
| body: | 316L |
| Valve seat: | PCTFE |
| Diaphragm: | Elgiloy® |
| Regulator materials | |
| body: | 316L / 316L secondary remelt |
| Valve seat: | PCTFE |
| Diaphragm: | Hastelloy® C276 |
| Leak rate: (to atmosphere) | 1x10 ⁻⁹ mbar l/s He |
| (via seat) | 1x10 ⁻⁸ mbar l/s He |



Dimensions (mm)

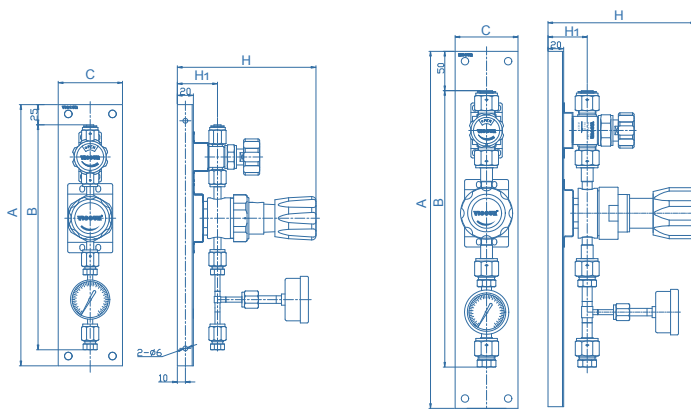

VUP-100TG (A Type)

VUP-200TG / VUP-300TG (A Type)

| Type | Panel Thickness mm | Ordering Number | Dimensions, mm | | | | |
|-------|--------------------|-----------------|----------------|-------|----|-------|----|
| | | | A | B | C | H | H1 |
| 100TG | 20 | VUP-100TG-A | 325 | 280 | 80 | 172.5 | 50 |
| 200TG | 20 | VUP-200TG-A | 455 | 352.4 | 80 | 188 | 50 |
| 300TG | 20 | VUP-300TG-A | 455 | 349.2 | 80 | 188 | 50 |

Gas Stick Assemblies VUP Series

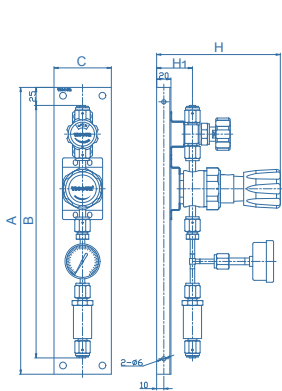

VUP-100TG (B Type)

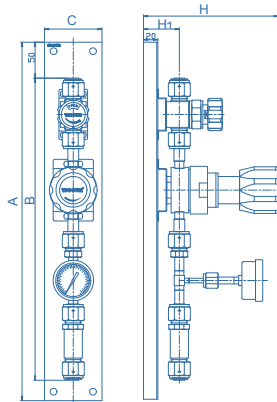

VUP-200TG / VUP-300TG (B Type)

| Type | Panel Thickness mm | Ordering Number | Dimensions, mm | | | | |
|-------|--------------------|-----------------|----------------|-------|----|-------|----|
| | | | A | B | C | H | H1 |
| 100TG | 20 | VUP-100TG-B | 400 | 352.3 | 80 | 172.5 | 50 |
| 200TG | 20 | VUP-200TG-B | 500 | 421.4 | 80 | 188 | 50 |
| 300TG | 20 | VUP-300TG-B | 500 | 418.2 | 80 | 188 | 50 |

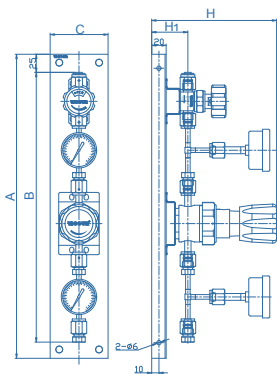

VUP-100TG (C Type)

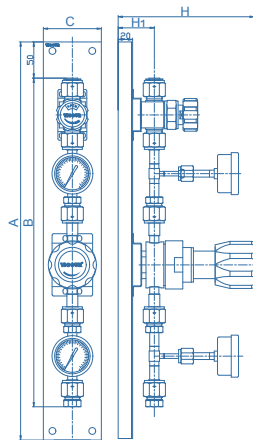

VUP-200TG / VUP-300TG (C Type)

| Type | Panel Thickness mm | Ordering Number | Dimensions, mm | | | | |
|-------|--------------------|-----------------|----------------|-------|----|-------|----|
| | | | A | B | C | H | H1 |
| 100TG | 20 | VUP-100TG-C | 420 | 372.6 | 80 | 172.5 | 50 |
| 200TG | 20 | VUP-200TG-C | 550 | 454.1 | 80 | 188 | 50 |
| 300TG | 20 | VUP-300TG-C | 550 | 447.7 | 80 | 188 | 50 |

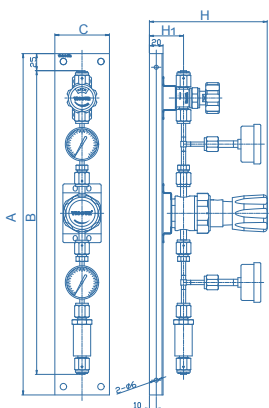

VUP-100TG (D Type)

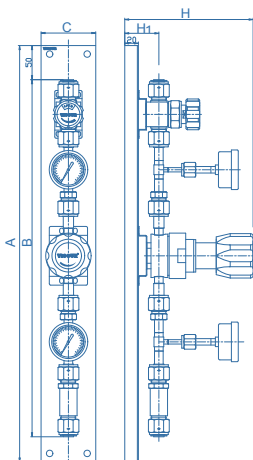

VUP-200TG / VUP-300TG (D Type)

| Type | Panel Thickness mm | Ordering Number | Dimensions, mm | | | | |
|-------|--------------------|-----------------|----------------|-------|----|-------|----|
| | | | A | B | C | H | H1 |
| 100TG | 20 | VUP-100TG-D | 500 | 444.9 | 80 | 172.5 | 50 |
| 200TG | 20 | VUP-200TG-D | 610 | 523.1 | 80 | 188 | 50 |
| 300TG | 20 | VUP-300TG-D | 610 | 516.7 | 80 | 188 | 50 |

Gas Stick Assemblies

VUP Series

Ordering Information

VUP - 100TG - D - 20 - 10 - FV4 - P - P - FV4 - F - PC

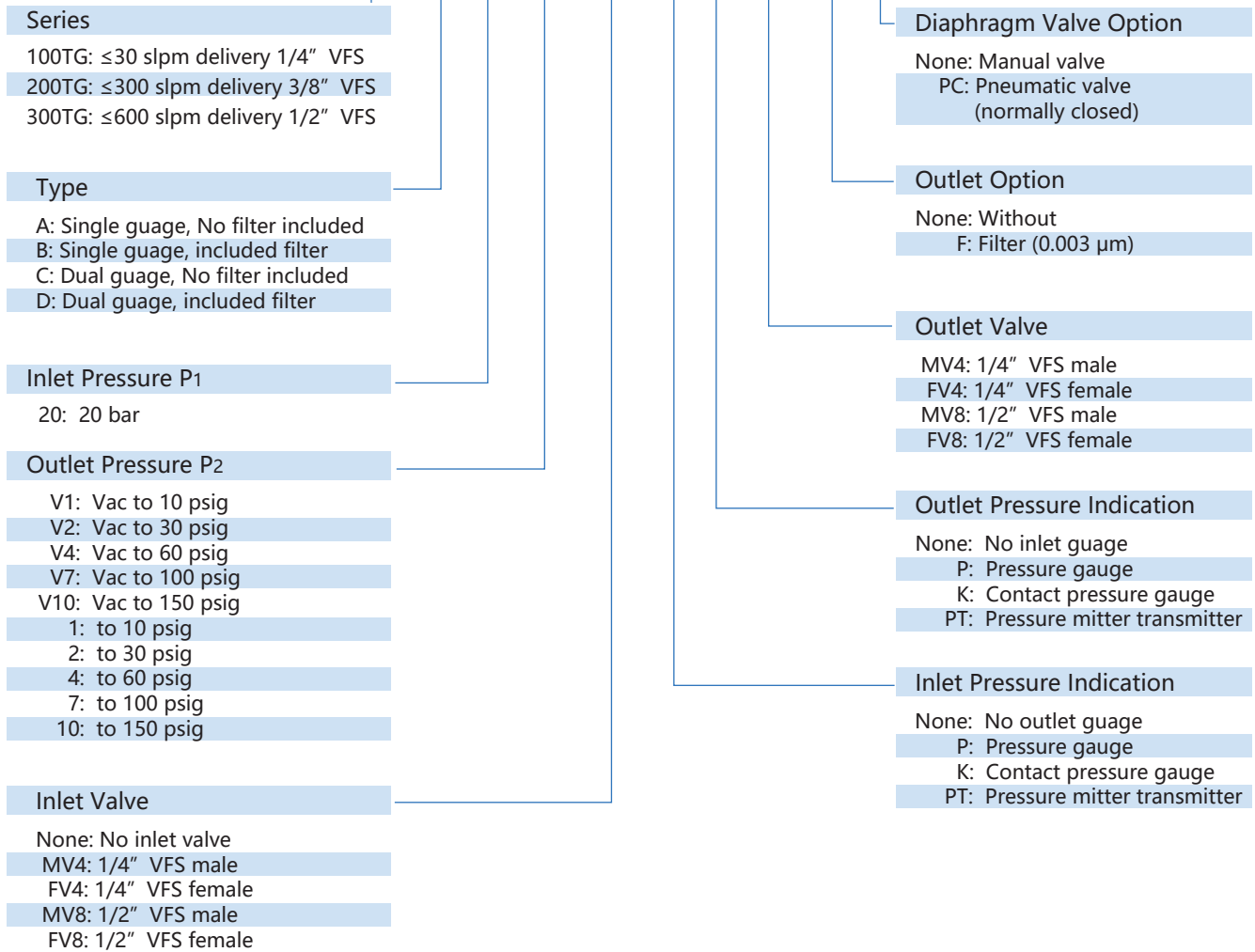

Product Feature

- The VFH Series is an In-Line filtration device
- Filter material: 316L
- Compact size and lightweight
- Outstanding chemical compatibility
- Tested for use with oxygen



In-line Type

Technical Data

| | |
|----------------------|------------------|
| Working Pressure: | 2350 psig |
| Working Temperature: | -10~100°C |
| Material | |
| Body: | SS 316L |
| Filter Element: | SS 316L |
| Gasket: | SS 316L / PTFE |
| End Connection: | Threaded Fitting |

Dimensions (mm)

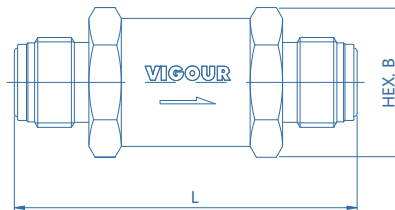

| End Connections | Dimensions (mm) | |
|-----------------|-----------------|----|
| | L | B |
| 1/4" VFS male | 81.8 | 26 |
| 1/2" VFS male | 84.6 | 32 |

Ordering Information

VFH - S - MV4 - MV4 - 2

| | |
|-------------------------|--|
| Material | S: 316L |
| Inlets / Outlets | MV4: 1/4" VFS male MV8: 1/2" VFS male |

| | |
|--------------------------|---|
| Nominal Pore Size | 0.5: 0.5 µm 2: 2 µm 5: 5 µm 10: 10 µm 20: 20 µm 40: 40 µm 70: 70 µm |
|--------------------------|---|

Gasket Filters VUGF Series

Product Feature

- All-metal filter
- Compact design
- Protect sensitive gas componers from particle damage
- Zntegrate into the gas system with out adding length
- Retain particles down to 0.3µm
- Dired with high purity nitrogen
- Fits in place of standard 1/4", 1/2" VFS Gasket



Flow Rata

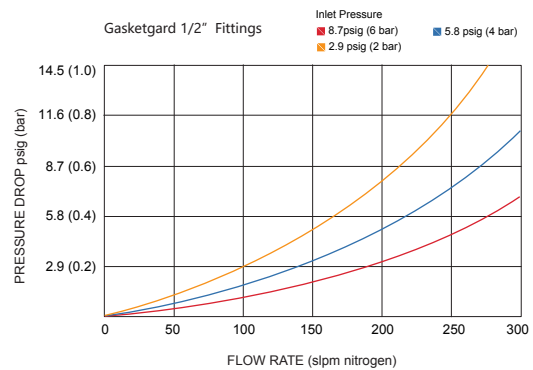
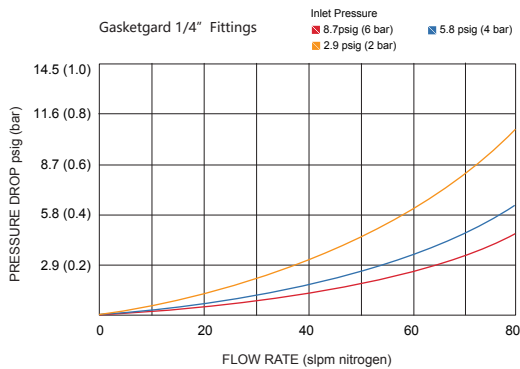

Dimensions (mm)

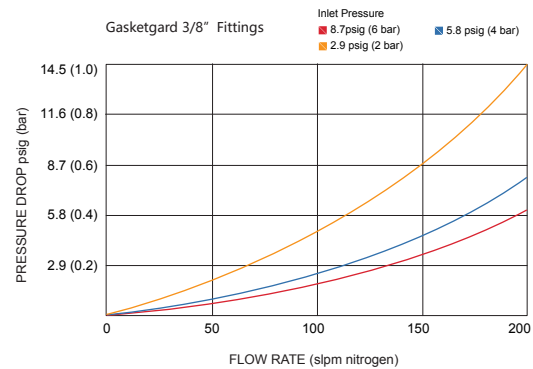
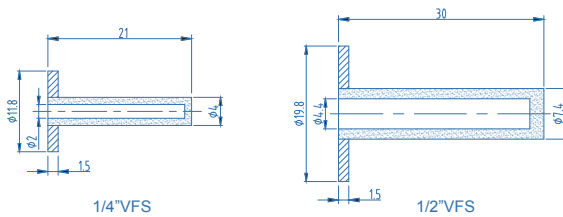

Ordering Information

VUGF - GK - G4

Gasket Option

GK: Gasket

GKR: Gasket Retainer Assembly

Option

G4: 1/4" VFS Gasket

G6: 3/8" VFS Gasket

G8: 1/2" VFS Gasket

General Information



Materials

| Material | Ordering Number Designator | Specification |
|---------------------------------------|----------------------------|---|
| Glands, Bodies, and Nuts | | |
| 316L stainless steel | Standard | Bar stock: ASME SA479, ASTM A276 Forgings: ASME A182 |
| 316L secondary remelt stainless steel | -SLV | Bar stock: ASME SA479, ASTM A276 Forgings: ASME A182 |
| Gaskets | | |
| Nickel | -NI | ASTM B162 |
| 316L stainless steel | Standard | ASTM A240, ASTM A167 |

Dimensions

- Dimensions are for reference only and are subject to change
- The D1 dimension refers to the smallest nominal inside diameter of the part

Pressure Ratings

- Ratings are based upon tests conducted using VFS assemblies
- All ratings comply with calculations per ANSI Code for Pressure Piping B31.3
- To determine pressure ratings in accordance with ANSI B31.3, multiply psig rating by 0.94
- Ratings determined at ambient temperature

| Components | Material | Temperature, °F (°C) |
|------------|---------------------------------------|----------------------|
| Fittings | 316L stainless steel | 1000 (537) |
| | 316L secondary remelt stainless steel | 1000 (537) |
| Gaskets | 316L stainless steel | 1000 (537) |
| | Nickel | 600 (315) |

Testing

The VFS assembly with silver plating has been helium leak tested to a rate of 4×10^{-9} mbar l/s He and the unplated gasket to a rate of 4×10^{-11} mbar l/s He without leakage.

Face Seal Fittings VVR Series

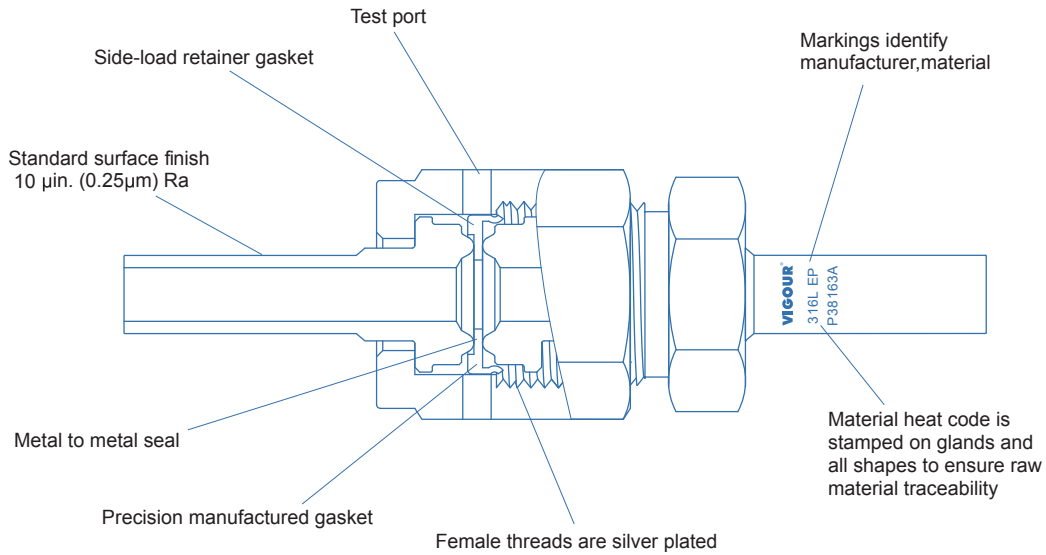

Typical VFS Assemblies

VFS assemblies are made up of four or five basic components.

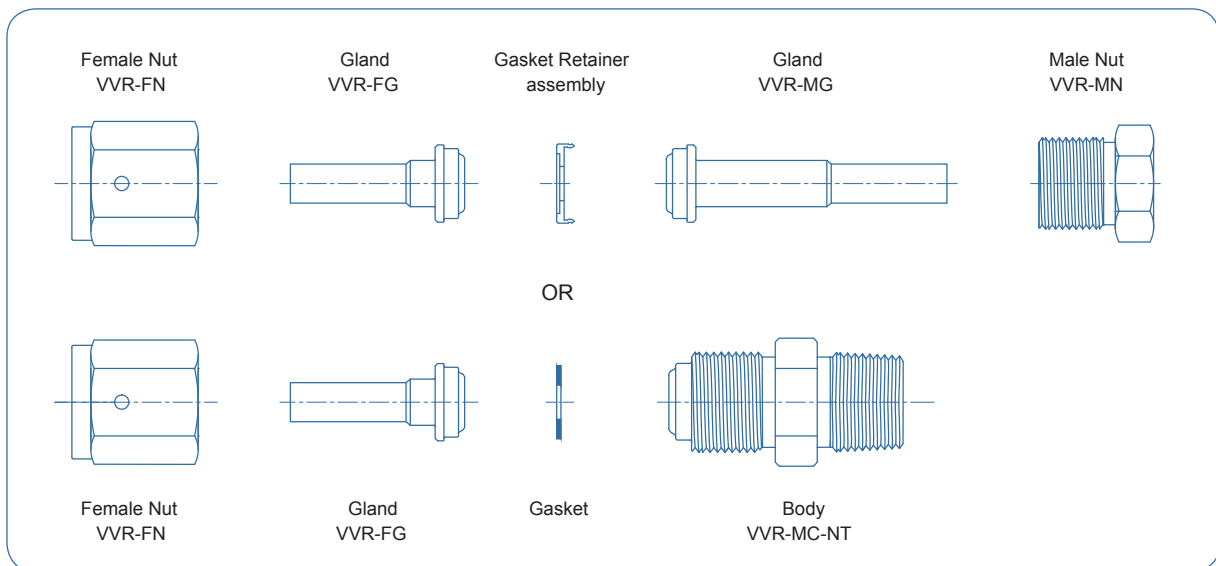

Glands

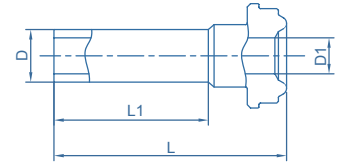

Short Tube Butt Weld

| D Tube OD in. | Wall Thickness in. | VFS Size in. | Material | Ordering Number | Dimensions, in.(mm) | | | Working Pressure psig (bar) |
|---------------------|--------------------------|--------------------|-----------------------|---------------------|---------------------|--------|--------|-----------------------------------|
| | | | | | L1 | D1 | L | |
| 1/8 | 0.028 | 1/8 | 316L | VVR-FG2-TB2 ① | 0.75 | 0.07 | 1.08 | 8500 |
| | | | 316L secondary remelt | VVR-FG2-TB2-SLV ① | (19.1) | (1.8) | (27.4) | (585) |
| 1/4 | 0.035 | 1/4 | 316L | VVR-FG4-TB4 | 0.75 | 0.18 | 1.10 | 5100 |
| | | | 316L secondary remelt | VVR-FG4-TB4-SLV | (19.1) | (4.6) | (27.9) | (351) |
| 1/4 | 0.035 | 1/4 | 316L | VVR-FG4-TB4-L18 | 0.38 | 0.18 | 0.72 | 5100 |
| | | | 316L secondary remelt | VVR-FG4-TB4-L18-SLV | (9.6) | (4.6) | (18.3) | (351) |
| 1/4 | 0.035 | 1/4 | 316L | VVR-FG4-TB4-L15 | 0.25 | 0.18 | 0.60 | 5100 |
| | | | 316L secondary remelt | VVR-FG4-TB4-L15-SLV | (6.4) | (4.6) | (15.2) | (351) |
| 1/4 | 0.035 | 1/2 | 316L | VVR-FG8-TB4 | 0.75 | 0.18 | 1.12 | 4300 |
| | | | 316L secondary remelt | VVR-FG8-TB4-SLV | (19.1) | (4.6) | (28.4) | (296) |
| 1/4 | 0.035 | 1/2 | 316L | VVR-FG8-TB4-L15 | 0.25 | 0.18 | 0.62 | 4300 |
| | | | 316L secondary remelt | VVR-FG8-TB4-L15-SLV | (19.1) | (4.6) | (15.7) | (296) |
| 1/4 | 0.035 | 1/2 | 316L | VVR-FG8-TB4-L19 | 0.75 | 0.18 | 0.76 | 4300 |
| | | | 316L secondary remelt | VVR-FG8-TB4-L19-SLV | (19.1) | (4.6) | (19.4) | (296) |
| 3/8 | 0.035 | 1/2 | 316L | VVR-FG8-TB6 | 0.75 | 0.31 | 1.12 | 3300 |
| | | | 316L secondary remelt | VVR-FG8-TB6-SLV | (19.1) | (7.9) | (28.4) | (227) |
| 3/8 | 0.035 | 1/2 | 316L | VVR-FG8-TB6-L15 | 0.25 | 0.31 | 0.62 | 3300 |
| | | | 316L secondary remelt | VVR-FG8-TB6-L15-SLV | (6.4) | (7.9) | (15.7) | (227) |
| 1/2 | 0.049 | 1/2 | 316L | VVR-FG8-TB8 | 0.75 | 0.40 | 1.12 | 3700 |
| | | | 316L secondary remelt | VVR-FG8-TB8-SLV | (19.1) | (10.2) | (28.4) | (254) |
| 1/2 | 0.049 | 1/2 | 316L | VVR-FG8-TB8-L18 | 0.38 | 0.40 | 0.74 | 3700 |
| | | | 316L secondary remelt | VVR-FG8-TB8-L18-SLV | (9.6) | (10.2) | (18.8) | (254) |
| 1/2 | 0.049 | 1/2 | 316L | VVR-FG8-TB8-L15 | 0.25 | 0.40 | 0.62 | 3700 |
| | | | 316L secondary remelt | VVR-FG8-TB8-L15-SLV | (6.4) | (10.2) | (15.7) | (254) |
| 3/4 | 0.049 | 3/4 | 316L | VVR-FG12-TB12 | 0.81 | 0.62 | 1.25 | 2400 |
| | | | 316L secondary remelt | VVR-FG12-TB12-SLV | (20.6) | (15.7) | (32) | (165) |
| 1 | 0.065 | 1 | 316L | VVR-FG16-TB16 | 0.75 | 0.87 | 1.51 | 1900 |
| | | | 316L secondary remelt | VVR-FG16-TB16-SLV | (19.1) | (22.1) | (38.6) | (130) |

① not design for gasket retainer assembly

To order fittings manufactured for Surface Finish Ra(Average)<0.4 add BA to the ordering number.
Example: VVR-FG4-TB4-BA

Face Seal Fittings

VVR Series

Glands

Long Tube Butt Weld

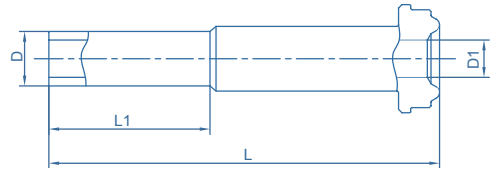

| D Tube OD in. | Wall Thickness in. | VFS Size in. | Material | Ordering Number | Dimensions, in.(mm) | | | Working Pressure psig (bar) |
|---------------------|--------------------------|--------------------|-----------------------|---------------------|---------------------|--------|--------|-----------------------------------|
| | | | | | L1 | D1 | L | |
| 1/8 | 0.028 | 1/8 | 316L | VVR-MG2-TB2 ① | 0.75 | 0.07 | 1.42 | 8500 |
| | | | 316L secondary remelt | VVR-MG2-TB2-SLV ① | (19.1) | (1.8) | (36.1) | (585) |
| 1/4 | 0.035 | 1/4 | 316L | VVR-MG4-TB4 | 0.75 | 0.18 | 1.70 | 5100 |
| | | | 316L secondary remelt | VVR-MG4-TB4-SLV | (19.1) | (4.6) | (43.2) | (351) |
| 1/4 | 0.035 | 1/4 | 316L | VVR-MG4-TB4-L33 | 0.38 | 0.18 | 1.32 | 5100 |
| | | | 316L secondary remelt | VVR-MG4-TB4-L33-SLV | (9.6) | (4.6) | (33.5) | (351) |
| 1/4 | 0.035 | 1/4 | 316L | VVR-MG4-TB4-L30 | 0.25 | 0.18 | 1.20 | 5100 |
| | | | 316L secondary remelt | VVR-MG4-TB4-L30-SLV | (6.4) | (4.6) | (30.5) | (351) |
| 1/4 | 0.035 | 1/2 | 316L | VVR-MG8-TB4 | 0.75 | 0.18 | 1.79 | 4300 |
| | | | 316L secondary remelt | VVR-MG8-TB4-SLV | (19.1) | (4.6) | (45.5) | (296) |
| 1/4 | 0.035 | 1/2 | 316L | VVR-MG8-TB4-L32 | 0.75 | 0.18 | 1.28 | 4300 |
| | | | 316L secondary remelt | VVR-MG8-TB4-L32-SLV | (19.1) | (4.6) | (32.7) | (296) |
| 1/4 | 0.035 | 1/2 | 316L | VVR-MG8-TB4-L37 | 0.75 | 0.18 | 1.47 | 4300 |
| | | | 316L secondary remelt | VVR-MG8-TB4-L37-SLV | (19.1) | (4.6) | (37.4) | (296) |
| 3/8 | 0.035 | 1/2 | 316L | VVR-MG8-TB6 | 0.75 | 0.31 | 1.79 | 3300 |
| | | | 316L secondary remelt | VVR-MG8-TB6-SLV | (19.1) | (7.9) | (45.5) | (227) |
| 3/8 | 0.035 | 1/2 | 316L | VVR-MG8-TB6-L32 | 0.25 | 0.31 | 1.29 | 3300 |
| | | | 316L secondary remelt | VVR-MG8-TB6-L32-SLV | (6.4) | (7.9) | (32.8) | (227) |
| 1/2 | 0.049 | 1/2 | 316L | VVR-MG8-TB8 | 0.75 | 0.40 | 1.79 | 3500 |
| | | | 316L secondary remelt | VVR-MG8-TB8-SLV | (19.1) | (10.2) | (45.5) | (241) |
| 1/2 | 0.049 | 1/2 | 316L | VVR-MG8-TB8-L35 | 0.38 | 0.40 | 1.41 | 3500 |
| | | | 316L secondary remelt | VVR-MG8-TB8-L35-SLV | (9.6) | (10.2) | (35.8) | (241) |
| 1/2 | 0.049 | 1/2 | 316L | VVR-MG8-TB8-L32 | 0.25 | 0.40 | 1.29 | 3500 |
| | | | 316L secondary remelt | VVR-MG8-TB8-L32-SLV | (6.4) | (10.2) | (32.8) | (241) |
| 3/4 | 0.065 | 3/4 | 316L | VVR-MG12-TB12 | 0.75 | 0.65 | 2.03 | 2400 |
| | | | 316L secondary remelt | VVR-MG12-TB12-SLV | (19.1) | (16.5) | (51.6) | (165) |
| 1 | 0.065 | 1 | 316L | VVR-MG16-TB16 | 0.75 | 0.87 | 2.32 | 2400 |
| | | | 316L secondary remelt | VVR-MG16-TB16-SLV | (19.1) | (22.1) | (58.9) | (165) |

① not design for gasket retainer assembly

To order fittings manufactured for Surface Finish Ra(Average)<0.4 add BA to the ordering number.
Example: VVR-MG4-TB4-BA

Male Nut

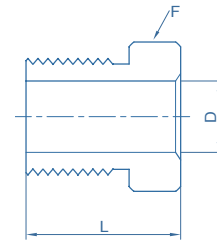

| VFS Size in. | Ordering Number | Material | F Hex Flat | Dimensions, in.(mm) | |
|--------------|-----------------|----------|------------|---------------------|-------------|
| | | | | L | D |
| 1/8 | VVR-MN2 | 316L | 3/8 | 0.50 (12.7) | 0.21 (5.3) |
| 1/4 | VVR-MN4 | | 5/8 | 0.71 (18.0) | 0.36 (9.1) |
| 1/2 | VVR-MN8 | | 15/16 | 0.81 (20.6) | 0.61 (15.5) |
| 3/4 | VVR-MN12 | | 1-5/16 | 1.00 (25.4) | 0.89 (22.6) |
| 1 | VVR-MN16 | | 1-5/8 | 1.19 (30.2) | 1.20 (30.5) |

Female Nut

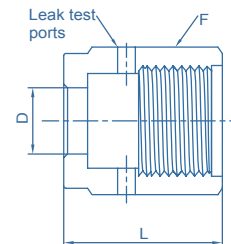

| VFS Size in. | Ordering Number | Material | F Hex Flat | Dimensions, in.(mm) | |
|--------------|-----------------|----------|------------|---------------------|-------------|
| | | | | L | D |
| 1/8 | VVR-FN2 | 316L | 7/16 | 0.53 (13.5) | 0.21 (5.3) |
| 1/4 | VVR-FN4 | | 3/4 | 0.81 (20.6) | 0.36 (9.1) |
| 1/2 | VVR-FN8 | | 1-1/16 | 0.88 (22.4) | 0.61 (15.5) |
| 3/4 | VVR-FN12 | | 1-1/2 | 1.12 (28.4) | 0.89 (22.6) |
| 1 | VVR-FN16 | | 1-3/4 | 1.34 (34.0) | 1.20 (30.5) |

Face Seal Fittings

VVR Series

Gasket Retainer Assembly

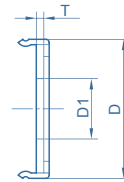

| VFS Size in. | Ordering Number | Material | Dimensions, in.(mm) | | |
|--------------|-----------------|----------|---------------------|-------------|-------------|
| | | | D1 | T | D |
| 1/4 | VVR-GKR-G4 | 316L | 0.24 (6.1) | 0.028 (0.7) | 0.50 (12.7) |
| | VVR-GKR-G4-NI | Nickel | | | |
| 1/2 | VVR-GKR-G8 | 316L | 0.44 (11.2) | 0.028 (0.7) | 0.79 (20.1) |
| | VVR-GKR-G8-NI | Nickel | | | |
| 3/4 | VVR-GKR-G12 | 316L | 0.66 (16.8) | 0.028 (0.7) | 1.14 (29.0) |
| | VVR-GKR-G12-NI | Nickel | | | |
| 1 | VVR-GKR-G16 | 316L | 0.89 (22.6) | 0.028 (0.7) | 1.40 (35.6) |
| | VVR-GKR-G16-NI | Nickel | | | |

Gaskets

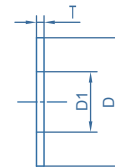

| VFS Size in. | Ordering Number | Material | Dimensions, in.(mm) | | |
|--------------|-------------------|----------|---------------------|-------------|-------------|
| | | | D1 | T | D |
| 1/8 | VVR-GK-G2 | 316L | 0.09 (2.3) | 0.028 (0.7) | 0.26 (6.6) |
| | VVR-GK-G2-NI | Nickel | | | |
| 1/4 | VVR-GK-G4 | 316L | 0.22 (5.6) | 0.028 (0.7) | 0.47 (11.9) |
| | VVR-GK-G4-NI | Nickel | | | |
| | VVR-GK-G4-12.7 | 316L | | | |
| | VVR-GK-G4-12.7-NI | Nickel | | | |
| 1/2 | VVR-GK-G8 | 316L | 0.44 (11.2) | 0.028 (0.7) | 0.78 (19.8) |
| | VVR-GK-G8-NI | Nickel | | | |
| 3/4 | VVR-GK-G12 | 316L | 0.66 (16.8) | 0.028 (0.7) | 1.14 (29.0) |
| | VVR-GK-G12-NI | Nickel | | | |
| 1 | VVR-GK-G16 | 316L | 0.89 (22.6) | 0.028 (0.7) | 1.40 (35.6) |
| | VVR-GK-G16-NI | Nickel | | | |

Filter Gaskets

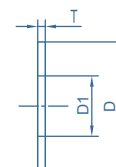

| VFS Size in. | Ordering Number | Material | Dimensions, in.(mm) | | |
|--------------|-----------------|----------|---------------------|-------------|-------------|
| | | | D1 | T | D |
| 1/4 | VVR-GKF-G4 | 316L | 0.22 (5.6) | 0.028 (0.7) | 0.47 (11.9) |
| | VVR-GKF-G4-NI | Nickel | | | |
| 1/2 | VVR-GKF-G8 | 316L | 0.44 (11.2) | 0.028 (0.7) | 0.78 (19.8) |
| | VVR-GKF-G8-NI | Nickel | | | |

* Element Nominal Pore Size (Option) : 0.5µm / 2µm / 5µm / 10µm / 20µm / 60µm
 Ordering Example: VVR-GKF-G4-0.5

Face Seal Fittings VVR Series

Cap

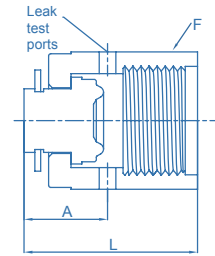

| VFS Size in. | Ordering Number | Material | Dimensions, in.(mm) | | |
|--------------|-----------------|----------|---------------------|-------------|-------------|
| | | | F Hex Flat | L | A |
| 1/8 | VVR-C2 | 316L | 7/16 | 0.63 (16.0) | 0.30 (7.6) |
| 1/4 | VVR-C4 | | 3/4 | 0.94 (23.9) | 0.44 (11.2) |
| 1/2 | VVR-C8 | | 1-1/16 | 1.01 (25.6) | 0.45 (11.4) |
| 3/4 | VVR-C12 | | 1-1/2 | 1.29 (32.8) | 0.54 (13.7) |
| 1 | VVR-C16 | | 1-3/4 | 1.54 (39.1) | 0.63 (16.0) |

Plug

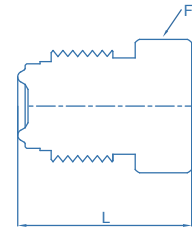

| VFS Size in. | Ordering Number | Material | Dimensions, in.(mm) | |
|--------------|---------------------|----------|---------------------|-------------|
| | | | F Hex Flat | L |
| 1/8 | VVR-P2 ^① | 316L | 3/8 | 0.68 (17.3) |
| 1/4 | VVR-P4 ^② | | 5/8 | 0.92 (23.4) |
| 1/2 | VVR-P8 | | 15/16 | 1.08 (27.4) |
| 3/4 | VVR-P12 | | 1-5/16 | 1.43 (36.3) |
| 1 | VVR-P16 | | 1-5/8 | 1.52 (38.6) |

① Not designed for gasket retainer assembly.

② Also available as a rotatable plug.
Ordering number: VVR-P8-R

Coupling

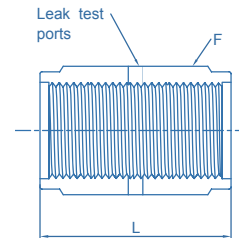

| VFS Size in. | Material | Ordering Number | Dimensions, in.(mm) | |
|--------------|----------|-----------------|---------------------|--------|
| | | | L | F |
| 1/8 | 316L | VVR-FU2 | 0.66 (16.8) | 7/16 |
| 1/4 | | VVR-FU4 | 1.19 (30.2) | 3/4 |
| 1/2 | | VVR-FU8 | 1.31 (33.3) | 1-1/16 |
| 3/4 | | VVR-FU12 | 1.68 (42.7) | 1-1/2 |
| 1 | | VVR-FU16 | 2.04 (51.8) | 1-3/4 |

Dimensions are for reference only and are subject to change without prior notice

Face Seal Fittings

VVR Series

Male NPT Connectors ^①

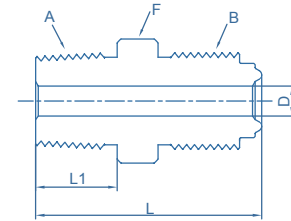

| A NPT Size in. | B VFS Size in. | Material | Ordering Number | Dimensions, in.(mm) | | | | Working Pressure psig (bar) | |
|-------------------------|-------------------------|----------|-------------------------|---------------------|-------------|-------------------------|--------|--------------------------------|------------|
| | | | | L | L1 | D | F | NI | SS |
| 1/16 | 1/8 | 316L | VVR-MC2-M1 ^① | 1.07 (27.2) | 0.38 (9.6) | 0.09 (2.3) ^③ | 3/8 | 9000 (620) | 9000 (620) |
| 1/8 | 1/8 | | VVR-MC2-M2 ^② | 1.07 (27.2) | 0.38 (9.6) | 0.09 (2.3) ^③ | 7/16 | 9000 (620) | 9000 (620) |
| 1/8 | 1/4 | | VVR-MC4-M2 | 1.31 (33.3) | 0.38 (9.6) | 0.18 (4.6) | 5/8 | 10000 (689) | 6400 (440) |
| 1/4 | 1/4 | | VVR-MC4-M4 | 1.49 (37.8) | 0.56 (14.2) | 0.18 (4.6) | 5/8 | 10000 (689) | 6400 (440) |
| 1/4 | 1/2 | | VVR-MC8-M4 | 1.65 (41.9) | 0.56 (14.2) | 0.28 (7.1) ^③ | 15/16 | 4300 (296) | 2800 (192) |
| 3/8 | 1/2 | | VVR-MC8-M6 | 1.65 (41.9) | 0.56 (14.2) | 0.38 (9.6) | 15/16 | 4300 (296) | 2800 (192) |
| 1/2 | 1/2 | | VVR-MC8-M8 | 1.84 (46.7) | 0.75 (19.1) | 0.4 (10.2) | 15/16 | 4300 (296) | 2800 (192) |
| 3/4 | 3/4 | | VVR-MC12-M12 | 2.19 (55.6) | 0.75 (19.1) | 0.62 (15.7) | 1-5/16 | 3700 (254) | 2400 (165) |
| 1 | 1 | | VVR-MC16-M16 | 2.47 (62.7) | 0.94 (23.9) | 0.87 (22.1) | 1-5/8 | 2400 (165) | 3000 (206) |

- ① VFS components with fixed threads must remain stationary during installation. These fitting connections should be assembled only to glands with rotating male or female threaded nuts.
- ② Not designed for gasket retainer assembly
- ③ May contain internal diameter transitions

To order fittings manufactured for Surface finish Ra(Average)<0.4 add BA to the ordering number.
Example: VVR-MC4-M4-BA

Female NPT Connectors ^①

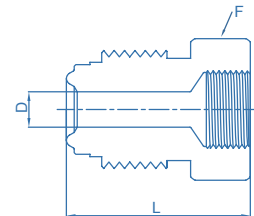

| NPT Size in. | VFS Size in. | Material | Ordering Number | Dimensions, in.(mm) | | | Working Pressure psig (bar) | |
|--------------------|--------------------|----------|-------------------------|---------------------|-------------|--------|--------------------------------|------------|
| | | | | L | D | F flat | NI | SS |
| 1/16 | 1/8 | 316L | VVR-MC2-F1 ^① | 1.10 (27.9) | 0.09 (2.3) | 7/16 | 6700 (461) | 6700 (461) |
| 1/8 | 1/8 | | VVR-MC2-F2 ^② | 1.19 (30.2) | 0.09 (2.3) | 9/16 | 6500 (447) | 6500 (447) |
| 1/8 | 1/4 | | VVR-MC4-F2 | 1.41 (35.8) | 0.18 (4.6) | 5/8 | 8000 (551) | 8000 (551) |
| 1/4 | 1/4 | | VVR-MC4-F4 | 1.54 (39.1) | 0.18 (4.6) | 3/4 | 6600 (454) | 6600 (454) |
| 3/8 | 1/2 | | VVR-MC8-F6 | 1.76 (44.7) | 0.40 (10.2) | 15/16 | 3500 (241) | 4300 (296) |
| 1/2 | 1/2 | | VVR-MC8-F8 | 1.99 (50.5) | 0.40 (10.2) | 1-1/16 | 3500 (241) | 4300 (296) |
| 3/4 | 3/4 | | VVR-MC12-F12 | 2.36 (59.9) | 0.62 (15.7) | 1-5/16 | 3000 (206) | 3700 (254) |
| 1 | 1 | | VVR-MC16-F16 | 2.51 (63.8) | 0.87 (22.1) | 1-5/8 | 2400 (165) | 3000 (206) |

- ① VFS components with fixed threads must remain stationary during installation. These fitting connections should be assembled only to glands with rotating male or female threaded nuts.
- ② Not designed for gasket retainer assembly

To order fittings manufactured for Surface finish Ra(Average)<0.4 add BA to the ordering number.
Example: VVR-MC4-F4-BA

Male Union ^①

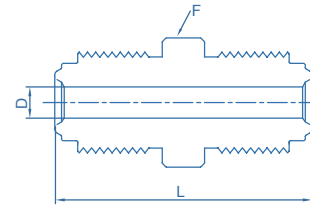

| VFS Size in. | Material | Ordering Number | Dimensions, in.(mm) | | | Working Pressure psig (bar) | |
|--------------|----------|----------------------|---------------------|-------------|--------|-----------------------------|-------------|
| | | | L | D | F | NI | SS |
| 1/8 | 316L | VVR-MU2 ^② | 1.13 (28.7) | 0.09 (2.3) | 3/8 | 9000 (620) | 11200 (771) |
| 1/4 | | VVR-MU4 | 1.55 (39.4) | 0.18 (4.6) | 5/8 | 8000 (551) | 10000 (689) |
| 1/2 | | VVR-MU8 | 1.84 (46.7) | 0.40 (10.2) | 15/16 | 3500 (241) | 4300 (296) |
| 3/4 | | VVR-MU12 | 2.44 (62.0) | 0.62 (15.7) | 1-5/16 | 3000 (206) | 3700 (254) |
| 1 | | VVR-MU16 | 2.59 (65.8) | 0.87 (22.1) | 1-5/8 | 2400 (165) | 3000 (206) |

① VFS components with fixed threads must remain stationary during installation.

These fitting connections should be assembled only to glands with rotating male or female threaded nuts.

② Not designed for gasket retainer assembly

To order fittings manufactured for Surface finish Ra(Average)<0.4 add BA to the ordering number.
Example: VVR-MU4-BA

Male Union Tee

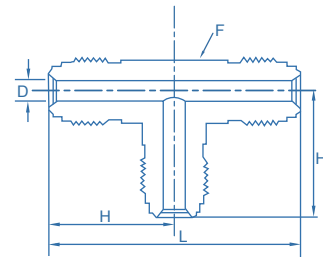

| VFS Size in. | Material | Ordering Number | Dimensions, in.(mm) | | | | Working Pressure psig (bar) | |
|--------------|----------|-----------------|---------------------|-------------|---------|-------------|-----------------------------|-------------|
| | | | L | D | F | H | NI | SS |
| 1/8 | 316L | VVR-MUT-2 | 1.78 (45.2) | 0.09 (2.3) | 7/16 | 0.89 (22.6) | 9000 (620) | 11200 (771) |
| 1/4 | | VVR-MUT-4 | 2.14 (54.4) | 0.18 (4.6) | 1/2 | 1.07 (27.2) | 8000 (551) | 10000 (689) |
| 1/2 | | VVR-MUT-8 | 2.90 (73.7) | 0.40 (10.2) | 13/16 | 1.45 (36.8) | 3500 (241) | 4300 (296) |
| 3/4 | | VVR-MUT-12 | 3.84 (97.5) | 0.62 (15.7) | 1-1/4 | 1.92 (48.8) | 3000 (206) | 3700 (254) |
| 1 | | VVR-MUT-16 | 4.00 (102) | 0.87 (22.1) | 1-11/16 | 2.00 (50.8) | 2400 (165) | 3000 (206) |

To order fittings manufactured for Surface finish Ra(Average)<0.4 add BA to the ordering number.
Example: VVR-MUT-4-BA

Fitting Lock Device

This device is intended for use on VIGOUR VFS metal gasket face seal assemblies with standard male and female nuts.



| Size in. | Material | Ordering Number |
|----------|----------|-----------------|
| 1/4 | 316 | VVR-FLD-4 |
| 1/2 | 316 | VVR-FLD-8 |

Micro Weld fittings

VMW Series

Union Elbow

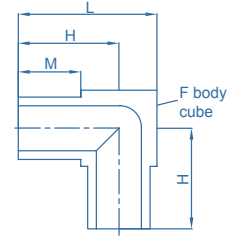

| Tube OD in. | Wall Thickness in. | Ordering Number | Dimensions, in.(mm) | | | | Working Pressure psig (bar) |
|-------------|--------------------|--------------------------|---------------------|---------------|-------|-------------|-----------------------------|
| | | | L | M | F | H | |
| 1/8 | 0.028 | VMW-UE2 VMW-UE2-SLV | 0.56 (14.2) | 0.25 (6.4) | 5/16 | 0.41 (10.4) | 8500 (585) |
| 1/4 | 0.035 | VMW-UE4 VMW-UE4-SLV | 0.56 (14.2) | | 5/16 | 0.41 (10.4) | 5100 (351) |
| 3/8 | 0.035 | VMW-UE6 VMW-UE6-SLV | 0.69 (17.5) | | 7/16 | 0.47 (11.9) | 3300 (227) |
| 1/2 | 0.049 | VMW-UE8 VMW-UE8-SLV | 0.81 (20.6) | | 9/16 | 0.53 (13.5) | 3700 (254) |
| 3/4 | 0.065 | VMW-UE12 VMW-UE12-SLV | 1.06 (27.0) | | 13/16 | 0.66 (16.6) | 2400 (165) |

To order fittings manufactured for Surface Finish Ra(Average)<0.4 add BA to the ordering number.
Example: VMW-UE6-BA

Reducing Elbow

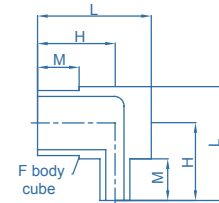

| Tube OD in. | Wall Thickness in. | Tube OD in. | Wall Thickness mm | Ordering Number | Dimensions, in.(mm) | | | | Working Pressure psig (bar) |
|-------------|--------------------|-------------|-------------------|----------------------------|---------------------|---------------|------|-------------|-----------------------------|
| | | | | | L | M | F | H | |
| 1/4 | 0.035 | 1/8 | 0.028 | VMW-RE4-2 VMW-RE4-2-SLV | 0.56 (14.2) | 0.25 (6.4) | 5/16 | 0.41 (10.3) | 3300 (227) |
| 3/8 | 0.035 | 1/4 | 0.035 | VMW-RE6-4 VMW-RE6-4-SLV | 0.69 (17.5) | | 7/16 | 0.47 (11.9) | 3300 (227) |
| 1/2 | 0.049 | 1/4 | 0.035 | VMW-RE8-4 VMW-RE8-4-SLV | 0.81 (20.6) | | 9/16 | 0.53 (13.5) | 3700 (254) |
| 1/2 | 0.049 | 3/8 | 0.035 | VMW-RE8-6 VMW-RE8-6-SLV | 0.81 (20.6) | | 9/16 | 0.53 (13.5) | 3300 (227) |

To order fittings manufactured for Surface Finish Ra(Average)<0.4 add BA to the ordering number.
Example: VMW-RE6-4-BA

Union Tee

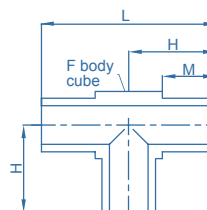

| Tube OD in. | Wall Thickness in. | Ordering Number | Dimensions, in.(mm) | | | | Working Pressure psig (bar) |
|-------------|--------------------|--------------------------|---------------------|------------|-------|-------------|-----------------------------|
| | | | L | M | F | H | |
| 1/8 | 0.028 | VMW-UT2 VMW-UT2-SLV | 0.82 (20.8) | 0.25 (6.4) | 5/16 | 0.41 (10.4) | 8500 (585) |
| 1/4 | 0.035 | VMW-UT4 VMW-UT4-SLV | 0.82 (20.8) | | 5/16 | 0.41 (10.4) | 5100 (351) |
| 3/8 | 0.035 | VMW-UT6 VMW-UT6-SLV | 0.94 (23.9) | | 7/16 | 0.47 (11.9) | 3300 (227) |
| 1/2 | 0.049 | VMW-UT8 VMW-UT8-SLV | 1.06 (26.9) | | 9/16 | 0.53 (13.5) | 3700 (254) |
| 3/4 | 0.065 | VMW-UT12 VMW-UT12-SLV | 1.31 (33.3) | | 13/16 | 0.65 (16.6) | 2400 (165) |

Reducing Tee

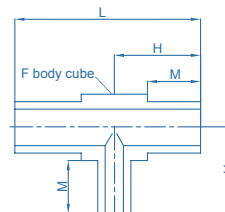

| Tube OD in. | Wall Thickness in. | Tube OD in. | Wall Thickness mm | Ordering Number | Dimensions, in.(mm) | | | | Working Pressure psig (bar) |
|-------------|--------------------|-------------|-------------------|----------------------------|---------------------|------------|------|-------------|-----------------------------|
| | | | | | L | M | F | H | |
| 1/4 | 0.035 | 1/8 | 0.028 | VMW-RT4-2 VMW-RT4-2-SLV | 0.81 (20.6) | 0.25 (6.4) | 5/16 | 0.41 (10.3) | 3300 (227) |
| 3/8 | 0.035 | 1/4 | 0.035 | VMW-RT6-4 VMW-RT6-4-SLV | 0.94 (23.9) | | 7/16 | 0.47 (11.9) | 3300 (227) |
| 1/2 | 0.049 | 1/4 | 0.035 | VMW-RT8-4 VMW-RT8-4-SLV | 1.06 (26.9) | | 9/16 | 0.53 (13.5) | 3700 (254) |
| 1/2 | 0.049 | 3/8 | 0.035 | VMW-RT8-6 VMW-RT8-6-SLV | 1.06 (26.9) | | 9/16 | 0.53 (13.5) | 3300 (227) |

To order fittings manufactured for Surface Finish Ra(Average)<0.4 add BA to the ordering number.
Example: VMW-RT6-4-BA

Tribow

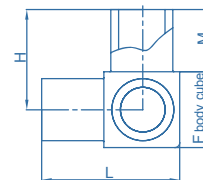

| Tube OD in. | Wall Thickness in. | Ordering Number | Dimensions, in.(mm) | | | | Working Pressure psig (bar) |
|-------------|--------------------|------------------------|---------------------|------------|------|-------------|-----------------------------|
| | | | L | M | F | H | |
| 1/4 | 0.035 | VMW-TB4 VMW-TB4-SLV | 0.56 (14.2) | 0.25 (6.4) | 5/16 | 0.41 (10.4) | 5100 (351) |
| 3/8 | 0.035 | VMW-TB6 VMW-TB6-SLV | 0.69 (17.5) | | 7/16 | 0.47 (11.9) | 3300 (227) |
| 1/2 | 0.049 | VMW-TB8 VMW-TB8-SLV | 0.81 (20.6) | | 9/16 | 0.53 (13.5) | 3700 (254) |

To order fittings manufactured for Surface Finish Ra(Average)<0.4 add BA to the ordering number.
Example: VMW-TB6-BA

Micro Weld fittings

VMW Series

Cross Union

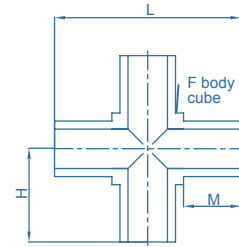

| Tube OD in. | Wall Thickness in. | Ordering Number | Dimensions, in.(mm) | | | | Working Pressure psig (bar) |
|-------------|--------------------|------------------------|---------------------|---------------|------|-------------|-----------------------------|
| | | | L | M | F | H | |
| 1/8 | 0.028 | VMW-CU2 VMW-CU2-SLV | 0.82 (20.8) | 0.25 (6.4) | 5/16 | 0.41 (10.4) | 8500 (585) |
| 1/4 | 0.035 | VMW-CU4 VMW-CU4-SLV | 0.82 (20.8) | | 5/16 | 0.41 (10.4) | 5100 (351) |
| 3/8 | 0.035 | VMW-CU6 VMW-CU6-SLV | 0.94 (23.9) | | 7/16 | 0.47 (11.9) | 3300 (227) |
| 1/2 | 0.049 | VMW-CU8 VMW-CU8-SLV | 1.06 (26.9) | | 9/16 | 0.53 (13.5) | 3700 (254) |

To order fittings manufactured for Surface Finish Ra(Average)<0.4 add BA to the ordering number.
Example: VMW-CU4-BA

Reducing Union

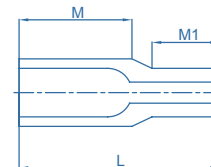

| Tube OD in. | Wall Thickness in. | Tube OD in. | Wall Thickness mm | Ordering Number | Dimensions, in.(mm) | | | Working Pressure psig (bar) |
|-------------|--------------------|-------------|-------------------|------------------------------|---------------------|----------------|---------------|-----------------------------|
| | | | | | L | M | M1 | |
| 1/4 | 0.035 | 1/8 | 0.028 | VMW-RU4-2 VMW-RU4-2-SLV | 0.75 (19.0) | 0.42 (10.7) | 0.25 (6.4) | 5100 (351) |
| 3/8 | 0.035 | 1/4 | 0.035 | VMW-RU6-4 VMW-RU6-4-SLV | | | | 3300 (227) |
| 1/2 | 0.049 | 1/4 | 0.035 | VMW-RU8-4 VMW-RU8-4-SLV | | | | 3700 (254) |
| 1/2 | 0.049 | 3/8 | 0.035 | VMW-RU8-6 VMW-RU8-6-SLV | | | | 3300 (227) |
| 3/4 | 0.065 | 1/4 | 0.035 | VMW-RU12-4 VMW-RU12-4-SLV | 0.75 (19.0) | 0.42 (10.7) | 0.25 (6.4) | 2400 (165) |
| 3/4 | 0.065 | 3/8 | 0.035 | VMW-RU12-6 VMW-RU12-6-SLV | | | | 2400 (165) |
| 3/4 | 0.065 | 1/2 | 0.049 | VMW-RU12-8 VMW-RU12-8-SLV | | | | 2400 (165) |

To order fittings manufactured for Surface Finish Ra(Average)<0.4 add BA to the ordering number.
Example: VMW-RU6-4-BA

Long Elbow 90°

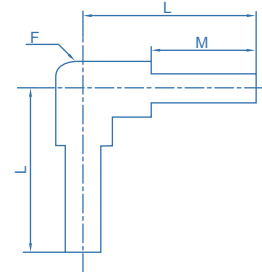

| Tube OD in. | Wall Thickness mm | Ordering Number | Dimensions, in.(mm) | | | Working Pressure psig (bar) |
|-------------|-------------------|-----------------|---------------------|-------------|-------|-----------------------------|
| | | | L | M | F | |
| 1/4 | 0.035 | VTW-LE4 | 1.23 (31.2) | 0.75 (19.0) | 7/16 | 5100 (351) |
| 3/8 | 0.035 | VTW-LE6 | 1.20 (30.5) | | 7/16 | 3300 (227) |
| 1/2 | 0.049 | VTW-LE8 | 1.34 (34.0) | | 11/16 | 3700 (254) |
| 3/4 | 0.049 | VTW-LE12 | 1.46 (37.1) | | 15/16 | 2400 (165) |
| 1 | 0.065 | VTW-LE16 | 1.34 (34.0) | | 1-1/4 | 1900 (130) |

To order fittings manufactured for Surface Finish Ra(Average)<0.4 add BA to the ordering number.
Example: VTW-LE4-BA

Reducing Long Elbow

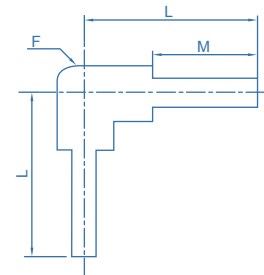

| Tube OD in. | Wall Thickness in. | Tube OD in. | Wall Thickness mm | Ordering Number | Dimensions, in.(mm) | | | Working Pressure psig (bar) |
|-------------|--------------------|-------------|-------------------|-----------------|---------------------|-------------|------------|-----------------------------|
| | | | | | L | M | F | |
| 3/8 | 0.039 | 1/4 | 0.039 | VTW-RLE6-4 | 0.98 (25) | 0.75 (19.0) | 6/16 | 3300 (227) |
| 1/2 | 0.049 | 1/4 | 0.039 | VTW-RLE8-4 | 1.06 (27) | | 7/16 | 3700 (254) |
| 1/2 | 0.049 | 3/8 | 0.039 | VTW-RLE8-6 | 1.06 (27) | | 7/16 | 3300 (227) |
| 3/4 | 0.065 | 1/4 | 0.039 | VTW-RLE12-4 | 1.24 (31.5) | | 15/16 | 2400 (165) |
| 3/4 | 0.065 | 3/8 | 0.039 | VTW-RLE12-6 | 1.24 (31.5) | | 15/16 | 2400 (165) |
| 3/4 | 0.065 | 1/2 | 0.049 | VTW-RLE12-8 | 1.24 (31.5) | 15/16 | 2400 (165) | |

To order fittings manufactured for Surface Finish Ra(Average)<0.4 add BA to the ordering number.
Example: VTW-RLE6-4-BA

Tube Butt Weld fittings

VTW Series

Long Tee

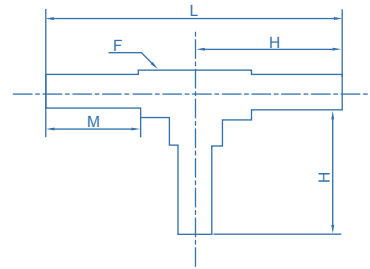

| Tube OD in. | Wall Thickness in. | Ordering Number | Dimensions, in.(mm) | | | | Working Pressure psig (bar) |
|-------------|--------------------|-----------------|---------------------|-------------|-------|-------------|-----------------------------|
| | | | L | M | F | H | |
| 1/4 | 0.035 | VTW-LT4 | 2.46 (62.5) | | 7/16 | 1.23 (31.2) | 5100 (351) |
| 3/8 | 0.035 | VTW-LT6 | 2.40 (61.0) | | 7/16 | 1.20 (30.5) | 3300 (227) |
| 1/2 | 0.049 | VTW-LT8 | 2.68 (68.1) | 0.75 (19.0) | 11/16 | 1.34 (34.0) | 3700 (254) |
| 3/4 | 0.049 | VTW-LT12 | 2.91 (73.9) | | 15/16 | 1.46 (37.1) | 2400 (165) |
| 1 | 0.065 | VTW-LT16 | 2.68 (68.1) | | 1-1/4 | 1.34 (34.0) | 1900 (130) |

To order fittings manufactured for Surface Finish Ra(Average)<0.4 add BA to the ordering number.
Example: VTW-LT4-BA

Reducing Long Tee

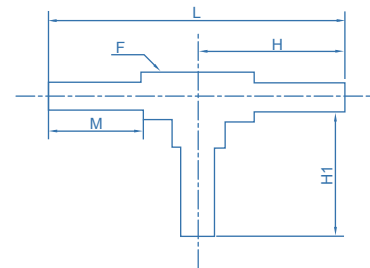

| Tube OD in. | Wall Thickness in. | Tube OD in. | Wall Thickness mm | Ordering Number | Dimensions, in.(mm) | | | | | Working Pressure psig (bar) |
|-------------|--------------------|-------------|-------------------|-----------------|---------------------|-------------|-------|-------------|-------------|-----------------------------|
| | | | | | L | M | F | H | H1 | |
| 3/8 | 0.035 | 1/4 | 0.035 | VTW-RLT6-4 | 2.39 (60.7) | | 7/16 | 1.20 (30.5) | 1.23 (31.2) | 3300 (227) |
| 1/2 | 0.049 | 1/4 | 0.035 | VTW-RLT8-4 | 2.67 (67.8) | | 11/16 | 1.34 (34.0) | 1.34 (34.0) | 3700 (254) |
| 1/2 | 0.049 | 3/8 | 0.035 | VTW-RLT8-6 | 2.67 (67.8) | | 11/16 | 1.34 (34.0) | 1.35 (34.3) | 3300 (227) |
| 3/4 | 0.049 | 1/4 | 0.035 | VTW-RLT12-4 | 2.91 (73.9) | 0.75 (19.0) | 15/16 | 1.46 (37.1) | 1.48 (37.6) | 2400 (165) |
| 3/4 | 0.049 | 3/8 | 0.035 | VTW-RLT12-6 | 2.91 (73.9) | | 15/16 | 1.46 (37.1) | 1.48 (37.6) | 2400 (165) |
| 3/4 | 0.049 | 1/2 | 0.049 | VTW-RLT12-8 | 2.48 (63.0) | | 15/16 | 1.24 (31.5) | 1.24 (31.5) | 2400 (165) |

To order fittings manufactured for Surface Finish Ra(Average)<0.4 add BA to the ordering number.
Example: VTW-RLT6-4-BA

Reducing Long Union

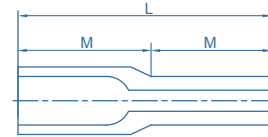

| Tube OD in. | Wall Thickness in. | Tube OD in. | Wall Thickness mm | Ordering Number | Dimensions, in.(mm) | | Working Pressure psig (bar) |
|-------------|--------------------|-------------|-------------------|-----------------|---------------------|-------------|-----------------------------|
| | | | | | L | M | |
| 3/8 | 0.035 | 1/4 | 0.035 | VTW-RLU6-4 | 1.50 (38.1) | 0.75 (19.0) | 3300 (227) |
| 1/2 | 0.049 | 1/4 | 0.035 | VTW-RLU8-4 | | | 3700 (254) |
| 1/2 | 0.049 | 3/8 | 0.035 | VTW-RLU8-6 | | | 3300 (227) |
| 3/4 | 0.049 | 1/4 | 0.035 | VTW-RLU12-4 | | | 2400 (165) |
| 3/4 | 0.049 | 3/8 | 0.035 | VTW-RLU12-6 | | | 2400 (165) |
| 3/4 | 0.065 | 1/2 | 0.049 | VTW-RLU12-8 | | | 2400 (165) |
| 1 | 0.065 | 1/4 | 0.035 | VTW-RLU16-4 | | | 2400 (165) |
| 1 | 0.065 | 3/8 | 0.049 | VTW-RLU16-6 | | | 2400 (165) |
| 1 | 0.065 | 1/2 | 0.049 | VTW-RLU16-8 | | | 2400 (165) |
| 1 | 0.065 | 3/4 | 0.049 | VTW-RLU16-12 | | | 2400 (165) |

To order fittings manufactured for Surface Finish Ra(Average) < 0.4 add BA to the ordering number.
Example: VTW-RLU6-4-BA

Weld Assemblies

VWR Series

Welded Assemblies

Female Elbow

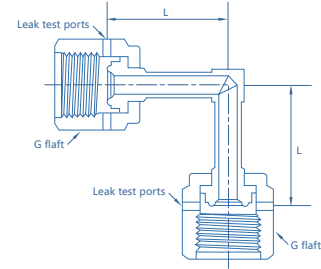

| VFS Size in. | Material | Ordering Number | Dimensions, in.(mm) | | Working Pressure psig (bar) | |
|--------------|----------|-----------------|---------------------|-----|-----------------------------|----------------|
| | | | L | G | Ni | 316L |
| 1/4 | 316L | VWR-FE4 | 1.00 (25.4) | 3/4 | 8000 (551) | 10000 (689) |

Female Tee

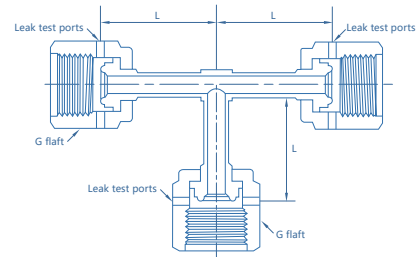

| VFS Size in. | Material | Ordering Number | Dimensions, in.(mm) | | Working Pressure psig (bar) | |
|--------------|----------|-----------------|---------------------|-----|-----------------------------|----------------|
| | | | L | G | Ni | 316L |
| 1/4 | 316L | VWR-FT4 | 1.00 (25.4) | 3/4 | 8000 (551) | 10000 (689) |

Product Feature

- Cylinder Connections
- Connect to a cylinder valve
- 1/4" NPT male / 6mm tube fitting / 6mm OD tube connection
- All connections are degrease to oxygen service
- 15µin. Ra max., 10µin. Ra average surface finish

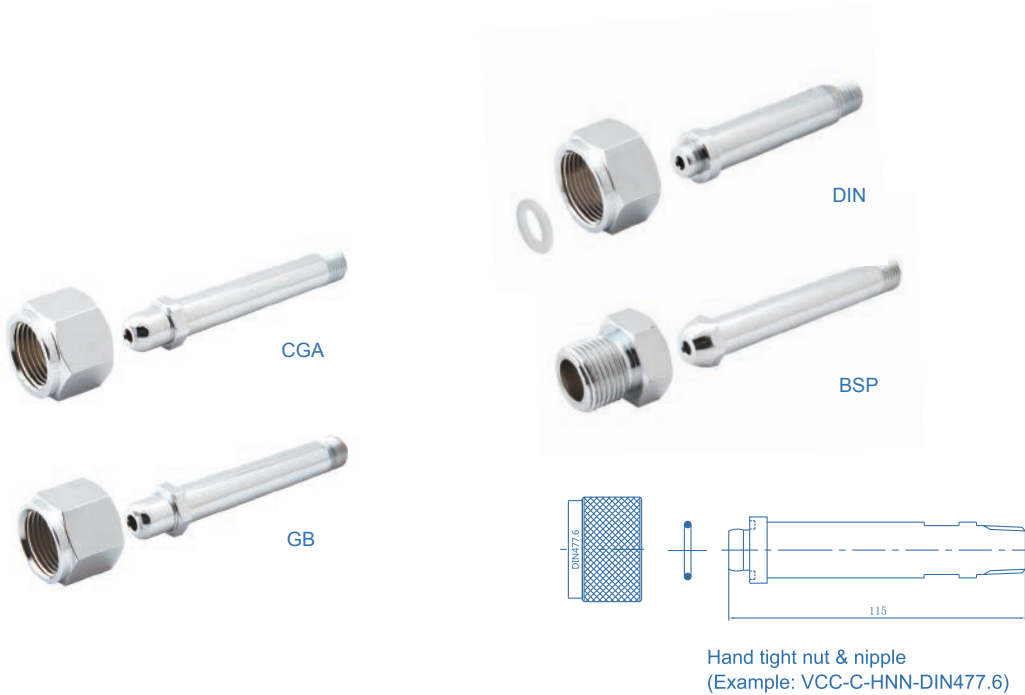

Ordering Information

VUC - S - N - CGA580 - TF6M

Material

S: 316L

Parts Code

N: nut
 NN: nut, nipple
 HN: hand tight nut
 HNN: hand tight nut, nipple
 NNP: nut, nipple, plug
 NNGP: nut, nipple, gasket, plug
 G: gasket

Inlet Connection

None: 1/4" NPT(M)
 6M: 6mm tube fitting
 TW6M: 6mm tube weld
 TW4: 1/4" tube weld

Cylinder Connection

Detailed description of the cylinder connection including the relevant standard and number of the connection

Cylinder Connections

VUC DISS Series

Technical Data

| | |
|----------------------------|----------------------|
| Materials of Construction | |
| Wetted | |
| Nuts | 316 Stainless Steel |
| Nipples | 316L Stainless Steel |
| Outlet Adapters | 316L Stainless Steel |
| Cylinder Valve Outlet Caps | 316L Stainless Steel |
| Gaskets | Nickel Standard* |

*Contact factory for other materials available.



Nut, Nipple and Nickel Gasket Assembly

| CGA/DISS Number | End Connection | F Hex Flat in. |
|-----------------|----------------|----------------|
| 632 ~ 642 | 1/4" Tube Weld | 1-1/4 |
| | 1/2" Tube Weld | |
| | 1/4" VFS Male | |
| | 1/4" NPT Male | |
| 712 ~ 728 | 1/4" Tube Weld | 1-3/8" |
| | 1/2" Tube Weld | |
| | 1/4" VFS Male | |
| | 1/4" NPT Male | |

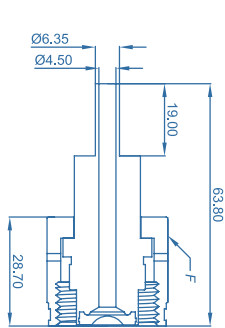

1/4" Tube Weld

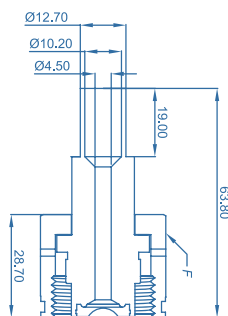

1/2" Tube Weld

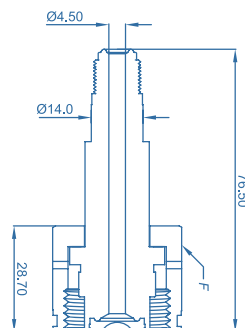

1/4" Face seal male

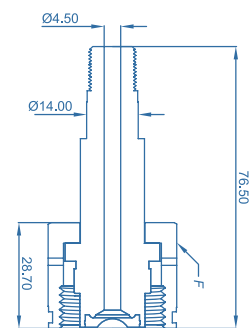

1/4" NPT Male

CAPS

| CGA/DISS Number | Ordering Number | Material | F Hex Flat in. | H Length in. | Gas Tight |
|-----------------|-----------------|----------------------|----------------|--------------|-----------|
| 632 ~ 642 | VUC-DISS-C-63 | Stainless Steel with | 1-1/4 | 0.98 | Yes |
| 712 ~ 728 | VUC-DISS-C-71 | Nickel gasket | 1-3/8 | | |

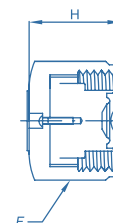

Cylinder Connections VUC DISS Series

GASKETS

| Material | Ordering Number | A | H | E |
|----------|-----------------|------|-------|------|
| Nickle | VUC-DISS-G-NI | 0.56 | 0.105 | 0.21 |
| PCTFE | VUC-DISS-G-PC | | 0.125 | |

* Hardness Max. 105 Vickers.

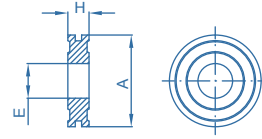

Plugs and Adapters

| CGA/DISS Number | Ordering Number | End Connection | H Overall Length | F Hex Flat in. |
|-----------------|------------------|-----------------|------------------|----------------|
| 632 ~ 642 | VUC-DISS-BP-63 | Plug | 1.53 | 1-1/8 |
| | VUC-DISS-A-F4-63 | 1/4" NPT Female | 1.85 | 1-1/8 |
| 712 ~ 728 | VUC-DISS-BP-71 | Plug | 1.53 | 1-1/4 |
| | VUC-DISS-A-F4-71 | 1/4" NPT Female | 1.85 | 1-1/4 |

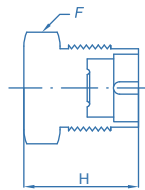

Plug

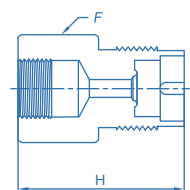

Adaptor

Ordering Information

VUC-DISS- NNG - CGA632 - TW4 - Ni

Parts Code

N: nut

P: nipple

NNG: nut, nipple, gasket

NNGP: nut, nipple, gasket, plug

CGA Number

CGA632 CGA642 CGA720

CGA634 CGA712 CGA722

CGA636 CGA714 CGA724

CGA638 CGA716 CGA726

CGA640 CGA718 CGA728

Gasket Material

Ni: Nickle

PC: PCTFE

End Connection

MV4: 1/4" VFS male

TW4: 1/4" tube weld

TW8: 1/2" tube weld

M4: 1/4" NPT male

* Other connection standard, consult factory

Pressure Gauge

VGU/VRU/VGT/VRT/VG/VR Series

Product Feature

- UHP “clean” for semiconductor gas applications, in accordance with SEMI/SEMATECH
- Purged with nitrogen
- Protective cap over threaded connection
- 100% factory calibrated and helium leak tested to a maximum rate of 1×10^{-9} mbar l/s He

Technical Data

| | |
|---------------------|--------------------------------|
| Type | pressure gauge |
| Materials: | |
| End connection | 316L VAR, electropolished |
| Bourdon tube | 316L SS |
| Case | 304 SS |
| Lens | polycarbonate |
| Movement | stainless steel |
| Dial & Pointer | aluminum |
| Scale | psig/bar dual scale |
| Dial size | 2" |
| Accuracy | Grade A per ASME B40.1 |
| Ambient temperature | -40°F to 140°F (-40°C to 60°C) |



VRU



VGU



VRT



VGT



VR



VG

Dimensions

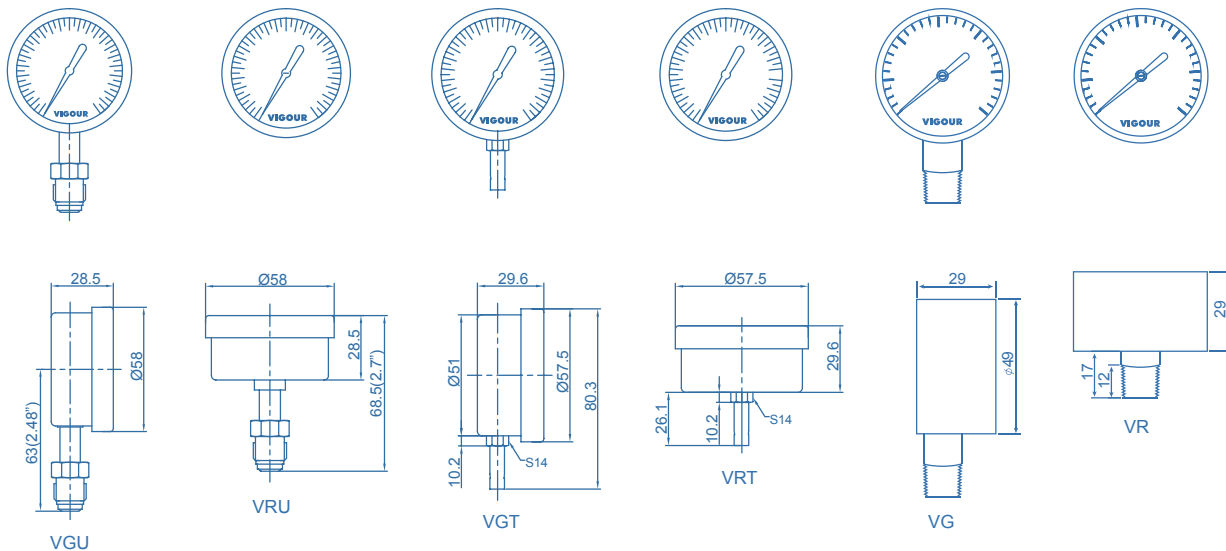

Ultra High Purity Gauge VGU/VRU/VGT/VRT/VGVR Series

Ordering Information

VGU/VRU Series (Ultra High Purity)

| Ordering Number | Inlet Connection | Pressure Range (bar/psig) |
|---|-------------------------|---|
| VGU Series, Lower Mount, VFS End | | |
| VGU20S-1.6/2.5/4/6/7/10/14/16/25/35/60B-FV4 | 1/4" VFS female | 0~1.6/2.5/4/6/7/10/14/16/25/35/60 bar 0~23/30/60/86/100/140/200/230/350/500/860 psig |
| VGU20S-1.6/2.5/4/6/7/10/14/16/25/35/60B-MV4 | 1/4" VFS male | |
| VGU20S-1.6/2.5/4/6/7/10/14/16/25/35/60B-RMV4 | 1/4" rotatable VFS male | |
| VGU20S-100/150/250/315/400B-FV4 | 1/4" VFS female | 0~100/150/250/315/400 bar 0~1500/2000/3500/4500/5800 psig |
| VGU20S-100/150/250/315/400B-MV4 | 1/4" VFS male | |
| VGU20S-100/150/250/315/400B-RMV4 | 1/4" rotatable VFS male | |
| VGU20S-V1.6/V2.5/V4/V6/V7/V10/V14/V16B-FV4 | 1/4" VFS female | Vac~1.6/2.5/4/6/7/10/14/16 bar Vac~23/30/60/86/100/140/200/230 psig |
| VGU20S-V1.6/V2.5/V4/V6/V7/V10/V14/V16B-MV4 | 1/4" VFS male | |
| VGU20S-V1.6/V2.5/V4/V6/V7/V10/V14/V16B-RMV4 | 1/4" rotatable VFS male | |
| VRU Series, Center-Back Mount, VFS End | | |
| VRU20S-1.6/2.5/4/6/7/10/14/16/25/35/60B-FV4 | 1/4" VFS female | 0~1.6/2.5/4/6/7/10/14/16/25/35/60 bar 0~23/30/60/86/100/140/200/230/350/500/860 psig |
| VRU20S-1.6/2.5/4/6/7/10/14/16/25/35/60B-MV4 | 1/4" VFS male | |
| VRU20S-1.6/2.5/4/6/7/10/14/16/25/35/60B-RMV4 | 1/4" rotatable VFS male | |
| VRU20S-100/150/250/315/400B-FV4 | 1/4" VFS female | 0~100/150/250/315/400 bar 0~1500/2000/3500/4500/5800 psig |
| VRU20S-100/150/250/315/400B-MV4 | 1/4" VFS male | |
| VRU20S-100/150/250/315/400B-RMV4 | 1/4" rotatable VFS male | |
| VRU20S-V1.6/V2.5/V4/V6/V7/V10/V14/V16B-FV4 | 1/4" VFS female | Vac~1.6/2.5/4/6/7/10/14/16 bar Vac~23/30/60/86/100/140/200/230 psig |
| VRU20S-V1.6/V2.5/V4/V6/V7/V10/V14/V16B-MV4 | 1/4" VFS male | |
| VRU20S-V1.6/V2.5/V4/V6/V7/V10/V14/V16B-RMV4 | 1/4" rotatable VFS male | |

VGT/VRT Series(Tube Connection)

| Ordering Number | Inlet Connection | Pressure Range (bar/psig) |
|--|------------------|---|
| VGT Series, Lower Mount, Tube End | | |
| VGT20S-1.6/2.5/4/6/7/10/14/16/25/35/60B-T4 | 1/4"tube | 0~1.6/2.5/4/6/7/10/14/16/25/35/60 bar 0~23/30/60/86/100/140/200/230/350/500/860 psig |
| VGT20S-1.6/2.5/4/6/7/10/14/16/25/35/60B-T6M | 6mm tube | |
| VGT20S-100/150/250/315/400B-T4 | 1/4"tube | |
| VGT20S-100/150/250/315/400B-T6M | 6mm tube | 0~100/150/250/315/400 bar 0~1500/2000/3500/4500/5800 psig |
| VGT20S-V2.5/V4/V16B-T4 | 1/4"tube | |
| VGT20S-V2.5/V4/V16B-T6M | 6mm tube | |
| VRT Series, Center-Back Mount, Tube End | | |
| VRT20S-1.6/2.5/4/6/7/10/14/16/25/35/60B-T4 | 1/4"tube | 0~1.6/2.5/4/6/7/10/14/16/25/35/60 bar 0~23/30/60/86/100/140/200/230/350/500/860 psig |
| VRT20S-1.6/2.5/4/6/7/10/14/16/25/35/60B-T6M | 6mm tube | |
| VRT20S-100/150/250/315/400B-T4 | 1/4"tube | |
| VRT20S-100/150/250/315/400B-T6M | 6mm tube | 0~100/150/250/315/400 bar 0~1500/2000/3500/4500/5800 psig |
| VRT20S-V1.6/V2.5/V4/V6/V7/V10/V14/V16B-T4 | 1/4"tube | |
| VRT20S-V1.6/V2.5/V4/V6/V7/V10/V14/V16B-T6M | 6mm tube | |

VG/VR Series(NPT Connection)

| Ordering Number | Inlet Connection | Pressure Range (bar/psig) |
|--|------------------|--|
| VG Series, Lower Mount, NPT End | | |
| VG20S-1.6/2.5/4/6/10/16/25/35/60B-M4 | 1/4"male NPT | 0~1.6/2.5/4/6/10/16/25/35/60 bar 0~23/30/60/86/140/230/350/500/860 psig |
| VG20S-100/150/250/315/400B-M4 | 1/4"male NPT | |
| VG20S-V1.6/V2.5/V4/V6/V10/V16B-M4 | 1/4"male NPT | |
| VR Series, Center-Back Mount, NPT End | | |
| VR20S-1.6/2.5/4/6/10/16/25/35/60B-M4 | 1/4"male NPT | 0~1.6/2.5/4/6/10/16/25/35/60 bar 0~23/30/60/86/140/230/350/500/860 psig |
| VR20S-100/150/250/315/400B-M4 | 1/4"male NPT | |
| VR20S-V1.6/V2.5/V4/V6/V10/V16B-M4 | 1/4"male NPT | |

Contact Gauges

VGU20SE / VRU20SE Series

Product Feature

- Contact gauge (KI) with inductance contact
- For monitoring gas supply pressure and shortage
- For inert, combustible, oxidizing, and corrosive gases and gas mixtures
- standard surface finish 10µin. (0.25µm) Ra
- Line 0.5m
- With NAMUR sensor
- Set point adjustable over 0~24% of scale
- Tested for use with oxygen

Typical Applications

Gas panels may be optionally equipped with contact pressure gauges. Contact pressure gauges combine the advantages of in situ readings with the demands of electrical signal transmissions. In combination with signal boxes, this creates visual and acoustic warning signals in the case of pressure drop and the monitoring of line pressure according to adjustable thresholds.



VGU



VRU

Technical Data

| | |
|---------------------|---------------------------------|
| Dual scale: | bar / psi |
| Connection: | 1/4" VFS Male / 1/4" VFS Female |
| Size: | 2" |
| Accuracy: | ±2.5% |
| Body Material: | 316L |
| Switching function: | NC |
| Outlet type: | NAMUR |
| Temperature: | -25~100°C |

Dimensions (mm)

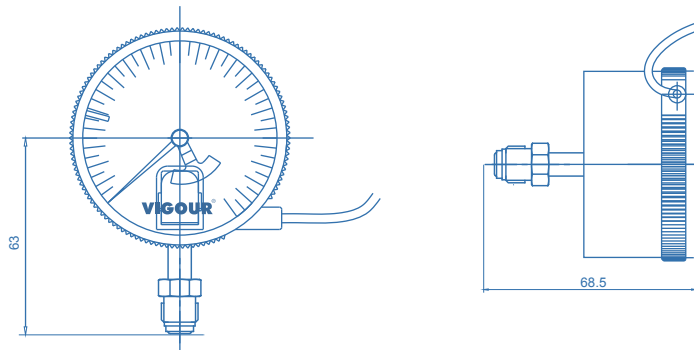

Ordering Information

VGU 20 SE - 400

Series

GU: radial direction

RU: axial direction

Material

S: 316L EP

Pressure Range

400: 0~400bar

250: 0~250bar

60: 0~60bar

25: 0~25bar

Contact Gauges VCG20S/VRG20S Series

Product Features

- Contact gauge (KI) with inductance contact
- For monitoring gas supply pressure and shortage
- For inert, combustible, oxidizing, and corrosive gases and gas mixtures
- standard surface finish 10µin. (0.25µm) Ra
- internals are electropolished to optionally meet purrty standards
- 100% helium-leak-tested

Typical Applications

Gas panels may be optionally equipped with contact pressure gauges. Contact pressure gauges combine the advantages of in situ readings with the demands of electrical signal transmissions. In combination with signal boxes, this creates visual and acoustic warning signals in the case of pres-sure drop and the monitoring of line pressure according to adjustable thresholds.



Technical Data

| | |
|---------------------|---|
| Dual scale: | bar / psi |
| Connection: | VFS connection |
| Size: | 2" |
| Accuracy: | Grade A per ASME B40.1 |
| Body Material: | 316L |
| Switching function: | NC / NO |
| Electrical rating | switching voltage ≤ AC 24V / DC 24V switching current ≤ 0.5A switching power ≤ 10VA / W |

Dimensions (mm)

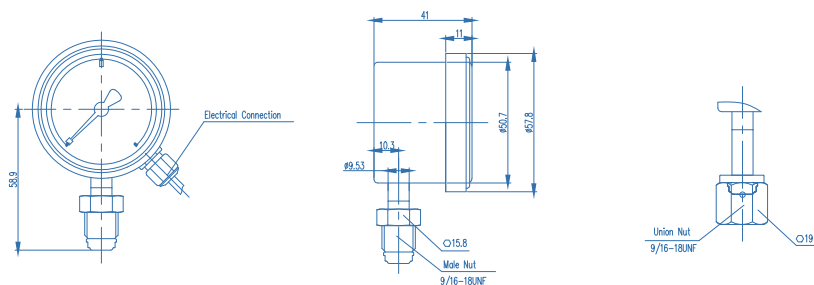

Ordering Information

VCG 20 S - 400

Series

CG: radial direction
RG: axial direction

Material

S: 316L EP

Pressure Range

400: 0~400bar
250: 0~250bar
60: 0~60bar
25: 0~25bar
V2.5 : Vac~2.5 bar
V4 : Vac~4 bar
V7 : Vac~7 bar
V10 : Vac~10 bar
V16 : Vac~16 bar
V25 : Vac~25 bar

Pressure

| | atm | bar | ft of H ₂ O | in of hg | in of H ₂ O | kg/cm ² | kPa | mm of Hg | PSI |
|------------------------|---------|----------|------------------------|----------|------------------------|--------------------|-----------|----------|----------|
| MULTIPLY | BY | | | | | | | | |
| atm | | 1.01325 | 33.932 | 29.921 | 407.1827 | 1.0332 | 101.3171 | 760 | 14.696 |
| bar | 0.98692 | | 33.4883 | 29.530 | 401.8596 | 1.019716 | 100 | 750.062 | 14.50368 |
| ft of H ₂ O | 0.02947 | 0.029891 | | 0.882646 | 12 | 0.03048 | 2.9890 | 22.4198 | 0.433107 |
| in of hg | 0.03342 | 0.033864 | 1.1340 | | 13.6 | 0.034532 | 3.376895 | 25.4 | 0.49115 |
| in of H ₂ O | 0.00246 | 0.002499 | 0.083333 | 0.073556 | | 0.00254 | 0.0249089 | 1.86832 | 0.03609 |
| kg/cm ² | 0.9678 | 0.980665 | 32.8084 | 28.95903 | 393.7008 | | 98.03922 | 735.5592 | 14.22334 |
| kPa | 0.00987 | 0.010 | 0.33456 | 0.29613 | 4.01472 | 0.01020 | | 7.5006 | 0.14504 |
| mm of Hg | 0.00132 | 0.001333 | 0.044603 | 0.03937 | 0.535240 | 0.001360 | 0.133322 | | 0.019337 |
| PSI | 0.06805 | 0.068948 | 2.3089 | 2.0360 | 27.70851 | 0.070307 | 6.89465 | 51.175 | |

Flow

| | cm ³ /min | cm ³ /sec | ft ³ /hr | ft ³ /min | m ³ /hr | m ³ /min | L/hr | Lpm |
|----------------------|----------------------|----------------------|---------------------|----------------------|--------------------|---------------------|----------|-----------|
| MULTIPLY | BY | | | | | | | |
| cm ³ /min | | 0.0166667 | 0.0021189 | 0.0000353 | 0.00006 | 0.000001 | 0.06 | 0.001 |
| cm ³ /sec | 60 | | 0.1271340 | 0.0021189 | 0.0036 | 0.00006 | 3.6 | 0.06 |
| ft ³ /hr | 471.9474 | 7.865790 | | 0.0166667 | 0.0283168 | 0.0004719 | 28.31685 | 0.4719474 |
| ft ³ /min | 28,316.85 | 471.9474 | 60 | | 1.699008 | 0.0283168 | 1699.008 | 28.31686 |
| m ³ /hr | 16,666.67 | 277.7778 | 35.31467 | 0.5885777 | | 0.0166667 | 1000 | 16.66667 |
| m ³ /min | 1,000,000 | 16,666.67 | 2118.876 | 35.31467 | 60 | | 60,000 | 1000 |
| L/hr | 16.66667 | 0.2777778 | 0.0353147 | 0.0005885 | 0.001 | 0.0000167 | | 0.0166667 |
| Lpm | 1000 | 16.66667 | 2.118876 | 0.0353147 | 0.06 | 0.001 | 60 | |

Density

| | gms/cm ³ | kg/m ³ | lbs/ft ³ | lbs/in ³ | lbs/U.S. gal |
|---------------------|---------------------|-------------------|---------------------|----------------------------|--------------|
| MULTIPLY | BY | | | | |
| gms/cm ³ | | 1000 | 62.428 | 0.0361273 | 8.3454 |
| kg/m ³ | 0.001 | | 0.062428 | 3.61273 x 10 ⁻⁵ | 0.0083454 |
| lbs/ft ³ | 0.0160185 | 16.018463 | | 5.78704 x 10 ⁻⁴ | 0.13368 |
| lbs/in ³ | 27.679905 | 27.679.9 | 1728 | | 231 |
| lbs/U.S. gal | 0.1198264 | 119.8264 | 7.4805195 | 0.004329 | |

Product Warranty Service

1. Warranty Term

One year after purchase. For any malfunction of a product purchased from VIGOUR that occurs during the warranty term as a result of failure, at the time of delivery, to fulfill the specifications intended, VIGOUR will repair or replace the product at no charge.

2. Range of Warranty

The warranty is limited to our products that were produced at and delivered from our VIGOUR.

Regardless of the warranty term, this warranty does not cover troubles or accidents, or any customer's opportunity loss, lost profit, secondary damage or damage to anything other than our products, as well as replacement work, readjustment of local machinery or equipment or trial operation by the customer. Safety management associated with the use of a product purchased from VIGOUR and peripheral equipment will be the responsibility of the user.

[Exclusions]

The warranty does not cover any of the following cases, even if it occurs during the term of the warranty.

- 1) Cases where failure occurs resulting from the replacement (maintenance) of parts by a person other than a VIGOUR engineer.
- 2) Cases where failure occurs due to a natural disaster or force majeure.
- 3) Cases where failure occurs due to misuse of the product or not taking the required precautions in handling the product.
- 4) Cases where the product is used or stored in an unsuitable environment.
- 5) Cases where the product is used for purposes other than the designated objectives, the product is used at a range exceeding the range of conditions specified in the design, or a purchased product is modified.
- 6) Cases where corrosion and failure occurs due to external factors or a corrosive liquid.
- 7) Any other case judged to be outside of the responsibility of VIGOUR.

VIGOUR[®]

Gas Control Solution

Email : info@vigourco.com
Website : www.vigourco.com

Office - GERMANY:

Fraunhoferstrasse 5
82152 Martinsried
Germany
Phone : +49 (0)89 / 74 49 26-0
Fax : +49 (0)89 / 74 49 26-10
Email : Europe@vigourco.com

Office – SINGAPORE:

NO.1 Sunview Road #03-46 Eco-Tech@
Sunview Singapore 627615
Phone : (65) 6255 2825
Fax : (65) 6255 2825
Email : Sales@vigourco.com.sg

Office - USA:

17912 Gothard Street
Huntington Beach
CA 92647
United State of America
Email : America@vigourco.com

Office - CHINA:

No. 201, Building 12, Lane 5355, Beisong Road,
SongJiang District, Shanghai China.
Email : China@vigourco.com
info@vigourco.com



pay attention to us
Get more product information

Distributed By :

NOTE:

Product availability and specifications contained herein are subject to change without notice.
Consult local distributor or factory for potential revisions and/or service related issues.

Copyright (c) 2019-2029 VIGOUR. All rights reserved. It is forbidden to copy, duplicate without the permission of the company.

VUPS Catalog EN Ver 4.0 CATA# **07062023**